

HOBO® Light On/Off Data Logger (UX90-002x) Manual



The HOBO Light On/Off data logger monitors indoor light changes with an internal sensor. Using HOBOWare®, you can easily configure the logger to record light on and off conditions making it ideal for building energy audits and light usage analysis. This compact data logger has a built-in LCD screen for checking status, remaining battery level, and memory consumption. You can also use the LCD screen to quickly calibrate the logger to the light level in your building or you can set calibration to preset sensitivity thresholds with HOBOWare. There are two models of the HOBO Light On/Off data logger: the UX90-002 has 128 KB of memory while the UX90-002M has 512 KB.

HOBO Light On/Off Data Logger

Models: UX90-002
UX90-002M

Included Items:

- Command™ strip
- Double-sided tape
- Hook & loop strap

Required Items:

- HOBOWare 3.3 or later
- USB cable (included with software)

Accessories:

- Light pipe (UX90-LIGHT-PIPE-1)
- U-Shuttle (U-DT-1)

Specifications

Light Threshold	> 65 lux
Light Type	LED, CFL, fluorescent, HID, incandescent, natural
Memory Modes	Wrap when full or stop when full
Start Modes	Immediate, push button, date & time, or next interval
Stop Modes	When memory full, push button, or date & time
Time Accuracy	±1 minute per month at 25°C (77°F) (see Plot A)
Power Source	One 3V CR2032 lithium battery and USB cable
Battery Life	1 year typical use
Memory	UX90-002: 128 KB (84,650 measurements, maximum) UX90-002M: 512 KB (346,795 measurements, maximum)
Download Type	USB 2.0 interface
Full Memory Download Time	10 seconds for 128 KB; 30 seconds for 512 KB
Logger Operating Range	Logging: -20° to 70°C (-4° to 158°F); 0 to 95% RH (non-condensing) Launch/Readout: 0° to 50°C (32° to 122°F) per USB specification
LCD	LCD is visible from: 0° to 50°C (32° to 122°F); the LCD may react slowly or go blank in temperatures outside this range
Size	3.66 x 5.94 x 1.52 cm (1.44 x 2.34 x 0.6 in.)
Weight	23 g (0.81 oz)
Environmental Rating	IP50
CE	The CE Marking identifies this product as complying with all relevant directives in the European Union (EU).

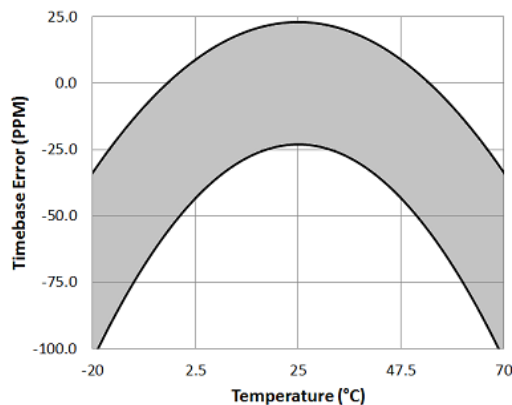

Plot A: Time Accuracy

Logger Components and Operation

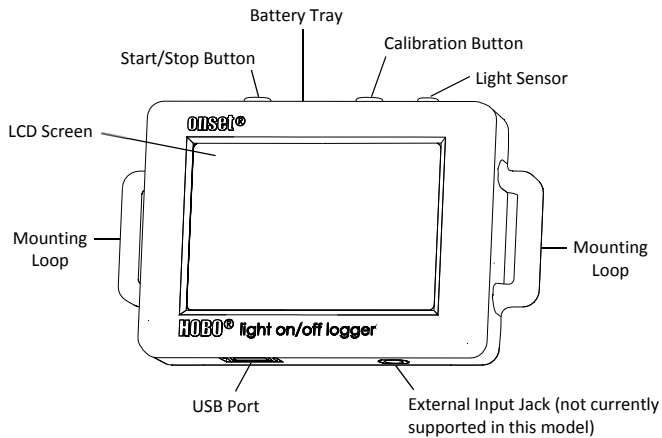

Start/Stop Button: Press this button for 3 seconds to start or stop logging data. This requires configuring the logger in HOBOWare with a push button start or stop (see *Setting up the Logger*). You can also press this button for 1 second to record an internal event (see *Recording Internal Logger Events*) or to turn the LCD screen on if the option to turn off the LCD has been enabled (see *Setting up the Logger*).

Battery Tray: Remove the battery tray (not visible in the diagram) on the top of the logger to access the logger battery (see *Battery Information*).

Calibration Button: Press this button to calibrate the logger for the light you will be monitoring. See *Calibrating the Light Sensor* for more details.

Light Sensor: This built-in sensor monitors light on and off conditions.







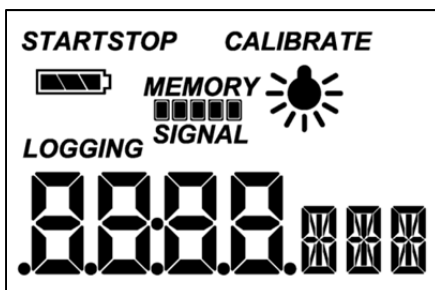

Mounting Loops: Use the two mounting loops to mount the logger with the hook-and-loop strap (see *Mounting the Logger*).

External Input Jack: This is not currently supported for this model. Check onsetcomp.com for new sensors for this model in the future.

USB Port: Use this port to connect the logger to the computer or the HOBOW U-Shuttle via USB cable (see *Setting up the Logger* and *Reading Out the Logger*).

LCD Screen: This logger is equipped with an LCD screen that displays details about the current status. This example shows all symbols illuminated on the LCD screen followed by definitions of each symbol in the following table.



LCD Symbol	Description
START	The logger is waiting to be launched. Press and hold the Start/Stop button for 3 seconds to launch the logger.
STOP	The logger has been launched with a push button stop enabled; press and hold the Start/Stop button for 3 seconds to stop the logger. Note: If you also launched the logger with a push button start, this symbol will not appear on the display for 5 minutes.
	The battery indicator shows the approximate battery power remaining.
MEMORY 	If the logger has been configured to stop logging when memory fills, the memory bar indicates the approximate space remaining in the logger to record data. In this example, the logger memory is almost full.
MEMORY 	If the logger has been configured to never stop logging (wrapping enabled), then a single block will blink starting at the left and moving right over time. Each block represents a segment of memory where the data is being recorded. In this example, the middle block is blinking.
	The light is on.
	The light is off.
LOGGING	The logger is currently logging.
CALIBRATE	The logger can be calibrated. See <i>Calibrating the Light Sensor</i> for more details.
 SIGNAL	This shows the signal strength of the light being monitored. In this example, the signal strength is at full scale. See <i>Calibrating the Light Sensor</i> for more details.
	Time display when logger is logging: This shows the total amount of time the light has been on since logging began, ranging from seconds to days. This example indicates the light has been on for a total of 5 minutes and 38 seconds. The logger must be launched with the LCD set to show "Time" for this symbol to display.
	Time display when logger is stopped: This indicates the logger has been configured to start logging on a particular date/time. The display will count down to the start date/time until logging begins. In this example, 5 minutes and 38 seconds remain until logging will begin.
	This shows the percentage of time the light has been on since logging began. This example indicates the light has been on for a total of 24% of the time since logging began. The logger must be launched with the LCD set to show "%" for this symbol to display.
Stop	The logger has been stopped.

Notes:

- You can disable the LCD screen when logging. Select "Turn LCD Off" when setting up the logger as described in the next section. When this option is enabled, you can still temporarily view the LCD screen by pushing the Start/Stop button or Calibration button for 1 second. The LCD will then remain on for 10 minutes.

- When the logger has stopped logging, the LCD screen will remain on until the logger is offloaded to a computer or HOBO U-Shuttle (unless launched with the “Turn LCD Off” option). Once the logger has been offloaded and disconnected from the computer, the LCD will turn off automatically after 2 hours. The LCD will turn back on the next time the logger is connected to the computer.

Setting up the Logger

Use HOBOWare to set up the logger, including configuring the sensor and selecting the start and stop logging options.

- 1. Connect the logger and open the Launch Logger window.** To connect the logger to a computer, plug the small end of the USB cable into the side of the logger and the large end into a USB port on the computer. Click the Launch icon on the HOBOWare toolbar or select Launch from the Device menu.

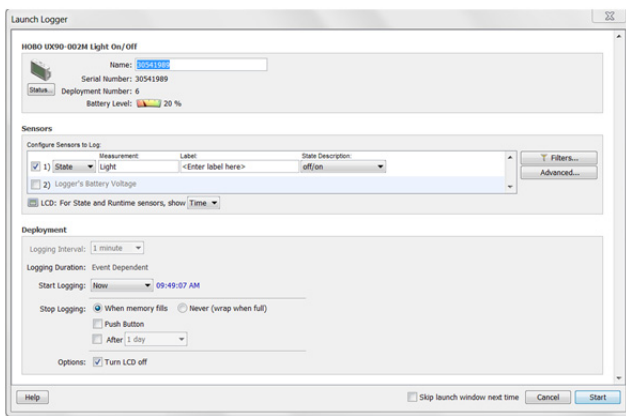

Important: USB 2.0 specifications do not guarantee operation outside the range of 0°C (32°F) to 50°C (122°F).

- 2. Configure the sensor.** Type a label for the sensor if desired and select the measurement type. The sensor can be configured to log:
 - **State.** This records how long an event lasts by storing the date and time when the state of the signal changes (logic state high to low or low to high). The logger checks every second for a state change, but will only record a time-stamped value when the state change occurs. One state change to the next represents the event duration.
 - **Runtime.** The logger checks the state of the line once every second. At the end of each logging interval, the logger records how many seconds the line was in the logic low state.
- 3. Configure optional filters as necessary.** Click the Filters button to create additional filtered data series based on the sensor configuration. Any filtered series will be automatically available upon reading out the logger.
- 4. Choose a calibration method with the Advanced settings.** The default method is to calibrate the logger using the calibrate button on the logger after it is launched. If you need to specify the sensitivity used for calibration, then click the Advanced button and select either a maximum or minimum level. See *Calibrating the Light Sensor* for more details.

- 5. Set the units to display on the LCD screen.** Select either Time or %.
- 6. If the logger is configured to record runtime, choose a logging interval from 1 second to a maximum of 18 hours, 12 minutes, and 15 seconds.**
- 7. Choose when to start logging:**
 - **Now.** Logging begins immediately.
 - **At Interval.** Logging will begin at the next even interval (available when logging runtime only).
 - **On Date/Time.** Logging will begin at a date and time you specify.
 - **Push Button.** Logging will begin once you press the Start/Stop logging button for 3 seconds.
- 8. Choose when to stop logging:**
 - **When Memory Fills.** Logging will end once the logger memory is full.
 - **Never (Wrap When Full).** The logger will continue recording data indefinitely, with newest data overwriting the oldest.
 - **Push Button.** Logging will end once you press the Start/Stop logging button for 3 seconds. Note that if you also choose Push Button to start logging, then you will not be able to stop logging until 5 minutes after logging begins.
 - **Specific Stop Date.** Logging will end at a date and time you specify.
- 9. Choose whether to keep the LCD on or off.** By default, the LCD will always remain on while logging. If you select the “Turn LCD off” checkbox, the LCD will not show the current readings, status, or other information while the logger is logging. You will, however, be able to temporarily turn the LCD screen on by pressing the Start/Stop button for 1 second if you select this option.
- 10. Click the Start button to launch the logger.** Disconnect the logger from the computer and deploy it using the mounting materials (see *Mounting the Logger*). After logging begins, you can read out the logger at any time (see *Reading Out the Logger* for details).

Determining Logging Duration

The logger’s storage capacity and logging duration depends on the interval between light on/off state changes. The longer the interval between the changes, the more memory is needed to store each data point. The following table shows how memory capacity is affected by the amount of time between light changes:

Time Between Events	Approximate Total Data Points	Approximate Logging Duration (1 Year Battery Life)	Logger Part Number
1 to 15 seconds	84,650	23.51 hours to 14.7 days	UX90-002
	346,795	4.01 to 60.21 days	UX90-002M
16 seconds to 4.25 minutes	63,488	11.76 to 187.38 days	UX90-002
	260,096	48.17 days to 2.1 years	UX90-002M

Time Between Events	Approximate Total Data Points	Approximate Logging Duration (1 Year Battery Life)	Logger Part Number
4.26 to 68.25 minutes	50,790 208,077	150.49 days to 6.6 years 1.69 years to 2.7 decades	UX90-002 UX90-002M
68.26 minutes to 18.2 hours	42,325 173,397	5.5 years to 8.8 decades 2.25 to 36.03 decades	UX90-002 UX90-002M

Notes:

- Typical battery life is 1 year when state changes are at 1 minute or greater intervals.
- The logger can record battery voltage data in an additional channel. This is disabled by default. Recording battery voltage reduces storage capacity and is generally not used except for troubleshooting.

Using the Logger with the Light Pipe

An optional fiber optic attachment or light pipe (UX90-LIGHT-PIPE-1) is available for this logger. This attachment connects to the back of the logger. To install it:

1. Locate the notch in the upper left corner next to the mounting magnet.

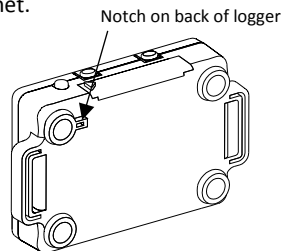

2. Insert the black base of the attachment into the notch so that the base clips onto the corner of the logger as shown below.

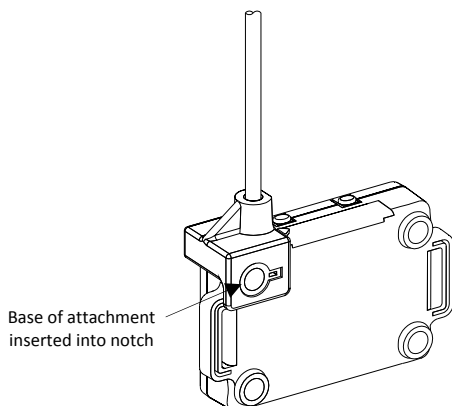

Follow these guidelines when using a light pipe:

- Make sure the end of the light pipe is as close to the light source as possible.
- Avoid 90-degree bends. The light pipe is flexible and can be bent to gain access to hard-to-reach areas, but should not have any sharp, 90-degree bends.

- Maximize the signal strength on the logger LCD screen by adjusting the light pipe while looking at the signal bars (see *Calibrating the Light Sensor* for more details on signal strength).
- Be sure to secure the light pipe after the signal has been optimized.
- Do not support the logger by the light pipe.
- Be sure that the pipe is seated all the way into the bracket before deployment.

Calibrating the Light Sensor

Each time you place the logger in a new lighted environment, you should calibrate it to the light level that you will be monitoring. This ensures the logger is accurately determining when the light changes between ON and OFF states. There are two calibration methods available: auto-calibration (button calibration) or preset calibration via HOBOWare.

Auto-calibration is used to calibrate the ON and OFF threshold of the logger to achieve reliable readings in an environment where ambient conditions are unknown prior to deployment or where logger light levels are variable. In the auto-calibration process, the light is measured via a built-in analog-to-digital converter and the resulting value is used to generate a calibration threshold. **Note:** Auto-calibration (button calibration) must be done at the location where the logger will be deployed.

Preset values are used when light levels are known in advance and deployment speed is critical.

The logger has a built-in hysteresis level of approximately $\pm 12.5\%$ to prevent the sensor from toggling between ON and OFF when the light level is near the calibration threshold. This plot shows how the logger handles hysteresis. The logger interprets the signal, or light, as ON until it drops below the lower level of the calibration threshold. Once it switches to off, the signal will not switch back to ON until it bypasses the upper limit of the calibration level.

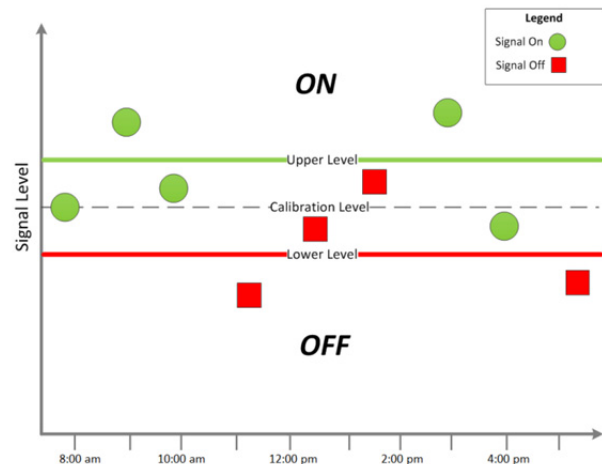

When auto-calibrating from the logger (button calibrating):

1. After launching, deploy the logger near the light source to be monitored and turn the light source on.

- Press the Calibrate button for 1 second. The LCD screen will display the signal strength of the light. The signal strength should ideally be at least 3 bars. Orient the logger as necessary to increase the signal strength.
- Press the Calibrate button for 3 seconds while "HOLD" appears on the LCD screen. Move your hand away from the logger to prevent shadowing. The logger will count down to the auto-calibration and then display either "PASS" or "FAIL" after calibration is complete.
- If the auto-calibration fails, point the sensor directly at the light source and then repeat these steps.

If you cannot manipulate the light source, you can set the calibration level in HOBOWare. To do this:

- Click the Advanced button in the Launch Logger window.
- The lower the light level, the higher the sensitivity needs to be to record changes between ON and OFF conditions. Therefore:
 - For rooms with low light levels, such as residential environments, select "Set to maximum sensitivity," which has a threshold set to approximately 100 lux.
 - For rooms with high light levels, such as retail environments, select "Set to minimum sensitivity," which has a threshold set to approximately 500 lux.

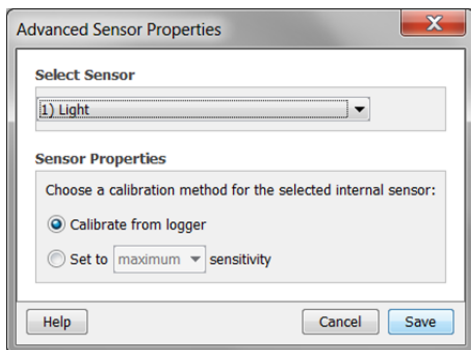

Note: The sensor is sensitive to lights that emit high amounts of infrared radiation like incandescent and halogen bulbs. It is best to use auto-calibration when possible when monitoring on/off conditions for lights with high infrared radiation.

- Click Save. Note that the selections will not take effect in the logger until you launch it.

Reading Out the Logger

There are two options for reading out the logger: connect it to the computer with a USB cable and read out it with HOBOWare, or connect it to a HOBO U-Shuttle (U-DT-1, firmware version 1.15m030 or higher) and then offload the data files from the U-Shuttle to HOBOWare. Refer to the HOBOWare Help for details.

Recording Internal Logger Events

The logger records the following internal events to help track logger operation and status:

Internal Event Name	Definition
Host Connected	The logger was connected to the computer.
Started	The Start/Stop button was pressed to begin logging.
Stopped	The logger received a command to stop recording data (from HOBOWare or by pushing the Start/Stop button).
Internal Calibration	The logger was calibrated via auto-calibration (button calibration).
Host Calibration	The logger was calibrated via HOBOWare.
Calibration Failure	Calibrating the logger has failed.
Button Up/Button Down	The Start/Stop button was pressed for 1 second.
Safe Shutdown	The battery level dropped below 2.5 V; the logger performs a safe shutdown.

Mounting the Logger

There are several ways to mount the logger using the materials included:

- Use the four built-in magnets on the back of the logger to mount it to a magnetic surface.
- Attach the Command strip to the back of the logger to mount it a wall or other flat surface.
- Use the double-sided tape to affix the logger to a surface.
- Insert the hook-and-loop strap through the mounting loops on both sides of the logger to mount it to a curved surface, such as a pipe or tubing.

Protecting the Logger

The logger is designed for indoor use and can be permanently damaged by corrosion if it gets wet. Protect it from condensation. If the message FAIL CLK appears on the LCD screen, there was a failure with the internal logger clock possibly due to condensation. Remove the battery immediately and dry the circuit board.

Note: Static electricity may cause the logger to stop logging.

The logger has been tested to 8 KV, but avoid electrostatic discharge by grounding yourself to protect the logger. For more information, search for "static discharge" in the FAQ section on onsetcomp.com.

Battery Information

The logger is installed with a 3V CR2032 battery (HRB-TEMP). Expected battery life varies based on the ambient temperature where the logger is deployed, the logging interval, the rate of state changes, the frequency of offloading to the computer, and battery performance. A new battery typically lasts 1 year with a logging interval greater than 1 minute. Deployments in extremely cold or hot temperatures or a logging interval faster than 1 minute may reduce battery life. Estimates are not guaranteed due to uncertainties in initial battery conditions and operating environment.

The logger can also be powered by the USB cable when the remaining battery voltage is too low for it to continue logging. Connect the logger to the computer, click the Readout button on the toolbar, and save the data as prompted. Replace the battery before launching the logger again.

To replace the battery:

1. Holding the logger with the LCD screen facing up, pull the battery tray out of the logger housing.

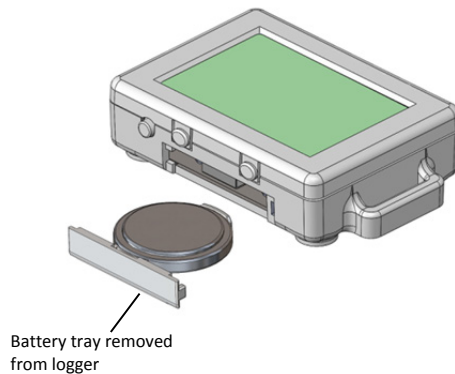

2. Remove the old battery from the tray.
3. Place the new battery in the tray with the positive side facing down.

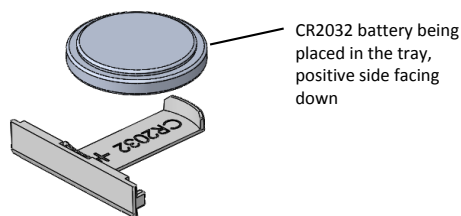

4. With the LCD screen still facing up, slide the tray back into the logger. The LCD should display "HOBO" briefly after correctly installing the battery.

⚠ WARNING: Do not cut open, incinerate, heat above 85°C (185°F), or recharge the lithium battery. The battery may explode if the logger is exposed to extreme heat or conditions that could damage or destroy the battery case. Do not dispose of the logger or battery in fire. Do not expose the contents of the battery to water. Dispose of the battery according to local regulations for lithium batteries.

HOBOWare provides the option of recording the current battery voltage at each logging interval, which is disabled by default. Recording battery life at each logging interval takes up memory and therefore reduces logging duration. It is recommended you only record battery voltage for diagnostic purposes.