

*Three axis (X, Y, Z) electromagnetic
field measurement*

3 D EMF TESTER

Model : EMF-828

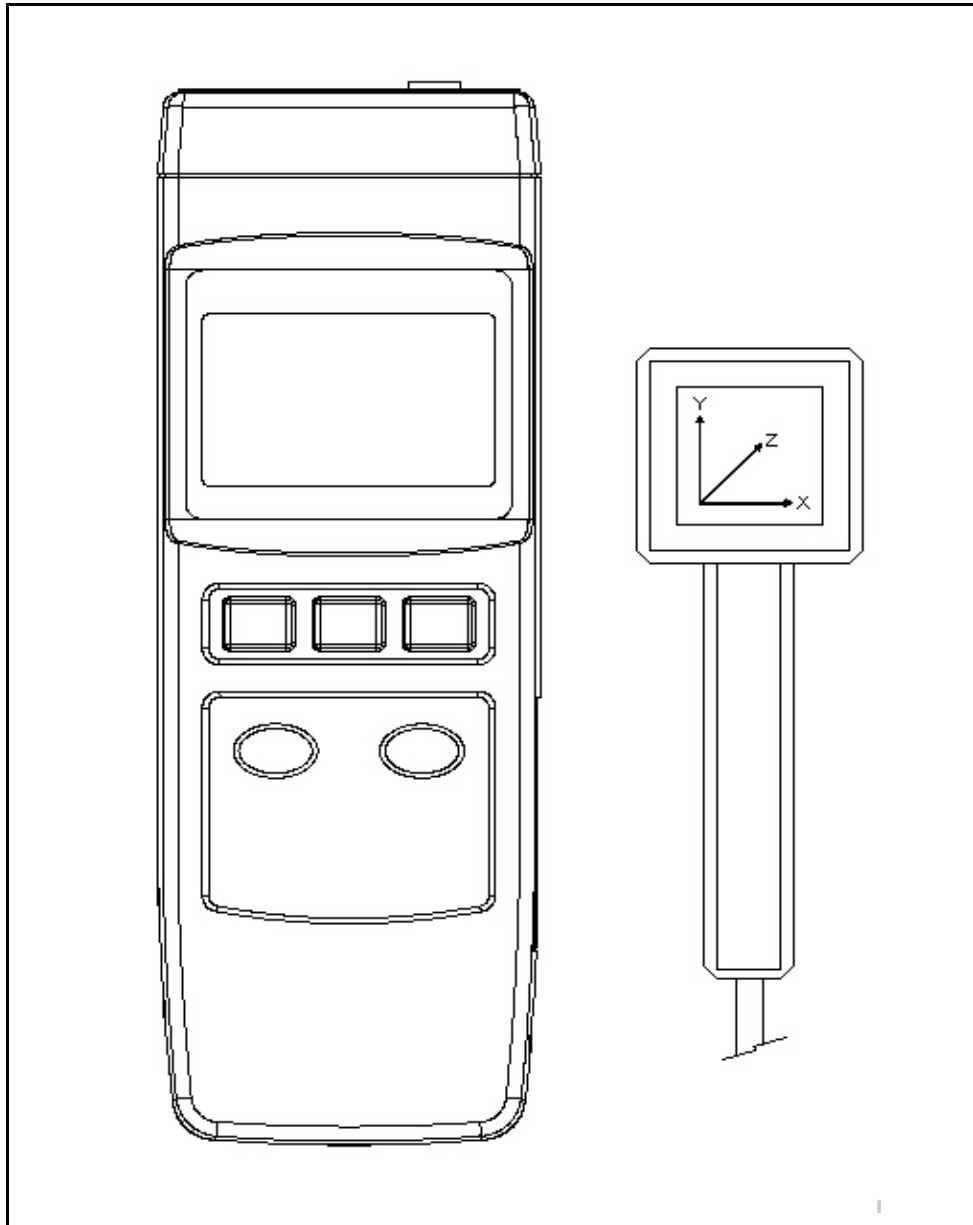

TABLE OF CONTENTS

1. FEATURES.....	1
2. APPLICATIONS.....	2
3. CAUTION OF ELECTROMAGNETIC FIELD EXPOSURE.....	2
4. SPECIFICATIONS.....	3
5. FRONT PANEL DESCRIPTION.....	5
5-1 Display.....	5
5-2 Power button.....	5
5-3 Hold button.....	5
5-4 XYZ axis select button.....	5
5-5 Unit button.....	5
5-6 Range button.....	5
5-7 Battery compartment/Cover.....	5
5-8 Stand.....	5
5-9 Probe input socket	5
5-10 Probe plug	5
5-11 Probe handle.....	5
5-12 Probe sensing head.....	5
6. MEASURING PROCEDURE.....	6
7. RECOMMENDATION.....	7
8. BATTERY REPLACEMENT.....	7

1. FEATURES

- * Three axis (X, Y, Z direction) electromagnetic field measurement.
- * The EMF tester is designed to provide user a quick, reliable and easy way to measure electromagnetic field radiation levels around power lines, electrical appliances and industrial devices.
- * Wide measuring ranges, 3 ranges of 20 micro Tesla, 200 micro Tesla & 2000 micro Tesla.
- * The EMF tester is a cost effective, hand-held instrument designed and calibrated to measure electromagnetic field radiation at wide bandwidths from 30 Hz to 300 Hz.
- * LCD display, jumbo digit size.
- * Data hold.
- * Separate probe, easy operation.
- * DC 9V battery power supply.
- * Hard case included.

2. APPLICATIONS

This EMF tester is specifically designed to determine the magnitude of electromagnetic field radiation generated by power lines, computer's monitor, TV sets, video machinery and many other similar devices.

3. CAUTION OF ELECTROMAGNETIC FIELD EXPOSURE

Claims by some scientists that long term exposure to electromagnetic field may be the cause of childhood leukemia & other forms of cancer.

Complete answers to any of these and related questions are not currently available. At the present time the most common practice is to avoid excess exposure over long period of time.

"Prudent Avoidance" as stated by the Environmental Protection Agency(EPA) USA is recommended.

4. SPECIFICATIONS

Display	LCD, 3 1/2 digits. LCD size : 55 mm x 47 mm. Max. indication 1999 counts. With display units.
Range / Resolution	<i>micro Tesla :</i> 20 micro Tesla/0.01 micro Tesla 200 micro Tesla/0.1 micro Tesla 2000 micro Tesla/1 micro Tesla
	<i>mili-Gauss :</i> 200 mili-Gauss/0.1 mili-Gauss 2,000 mili-Gauss/1 mili-Gauss 20,000 mili-Gauss/10 mili-Gauss
Number of Axis	Three axis (X, Y, Z direction). Axis selected by push button.
Band width	30 Hz to 300 Hz.
Accuracy	± (4 % + 3 d) <i>@ 20 micro Tesla range</i> <i>@ 200 mili-Gauss range</i>
	± (5 % + 3 d) <i>@ 200 micro Tesla range.</i> <i>@ 2,000 mili-Gauss range</i>
	± (10 % + 5 d) <i>@ 2,000 micro Tesla range.</i> <i>@ 20,000 mili-Gauss range</i>
	* Spec. accuracy tested under 50 Hz or 60 Hz. * Spec. tested under the environment RF Field Strength less than 3 V/M & frequency less than the 30 MHz only.

Over-input	Display shows " 1 " .
Sampling Time	Approx. 0.4 second.
Battery	DC 9 V battery (006P, 6F22).
Power Current	Approx. DC 2.7 mA.
Operating Temp.	0 to 50 °C (32 to 122 °F).
Operating Humidity	Less than 85 %RH.
Weight	460 g/1.01 LB (including battery). <i>@ Including Probe and battery</i>
Dimension	Main meter : 195 x 68 x 30 mm (7.6 x 2.6 x 1.2 inch)
	Probe : 70 x 58 x 220 mm (2.8 x 2.3 x 8.7 inch). <i>@ Sensor probe head : 70 x 58 mm.</i>
Probe Cable Length	930 mm.
Accessories Included	Operation Manual..... 1 PC
	Carrying case..... 1 PC

5. FRONT PANEL DESCRIPTION

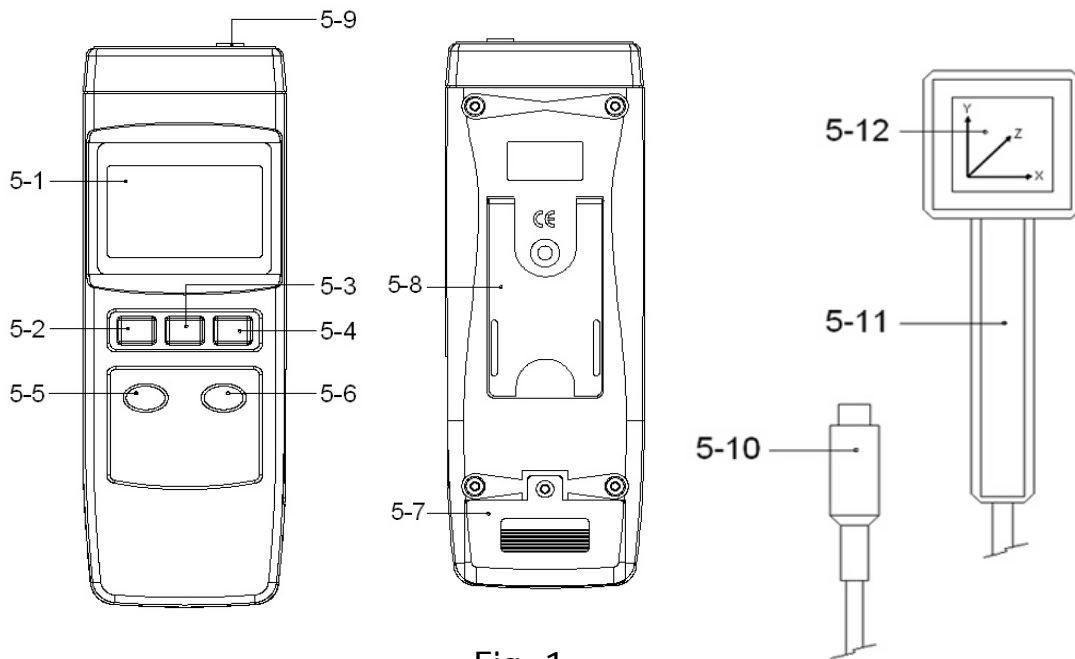

Fig. 1

- 5-1 Display
- 5-2 Power button
- 5-3 Hold button
- 5-4 XYZ axis select button
- 5-5 Unit button
- 5-6 Range button
- 5-7 Battery compartment/Cover
- 5-8 Stand
- 5-9 Probe input socket
- 5-10 Probe plug
- 5-11 Probe handle
- 5-12 Probe sensing head

6. MEASURING PROCEDURE

- 1) Power ON the meter by pushing the " Power button " (5-2, Fig. 1).
- 2) Select the desired unit (micro Tesla or mili-Gauss) by pushing the " Unit button " (5-5, Fig. 1).
- 3) Use the " Range button " (5-6, Fig. 1) to select the suitable range. For the unknown EMF measurement, start with the highest range and keep decreasing until the higher resolution's reading is obtained.
- 4) Hold the " Probe handle " (5-11, Fig. 1), move the " Probe sensing head " (5-12, Fig. 1) slowly towards to the object under measurement until it is physically touched.
- 5) Use the " XYZ axis select button " (5-4, Fig. 1) to select the EMF value in the X, Y or Z axis.

Note :

@ Due to the electromagnetic interference of the environment, the display reading may show small values before testing, for example less than 0.05 micro Tesla. This is not malfunction of the tester.

@ If the object under measurement is turned off during the measurement, the EMF tester reading should then return to zero, unless a field from other sources are detected.

- 6) During the measurement, if push the " Hold button " (5-3, Fig. 1) will freeze the display value. Push the " Hold button " again will release the Hold function.

7. RECOMMENDATION

It is recommended to measure the presence of the electromagnetic field inside and outside of your home and business locations regularly.

As "hot spots" are detected by the EMF tester, re-arrangement of the living and working areas is lightly recommended. Always try the best to avoid long term exposure to strong electromagnetic field.

8. BATTERY REPLACEMENT

- 1) When the left corner of LCD display show "  ", it is necessary to replace the battery. However, in-spec. measurement may still be made for several hours after low battery indicator appears before the instrument become inaccurate.
- 2) Slide the " Battery Cover " (5-7, Fig. 1) away from the instrument and remove the battery.
- 3) Replace with 9V battery (Alkaline or Heavy duty type) and reinstate the cover.
- 4) Make sure the battery cover is secured after changing the battery.