

of this tipping time water flows into the empty bucket. The amount of water flowing during the first 50% of time is error, the faster the flow rate the greater the error. At flow rates of one inch per hour (20 mm/hr) or less, the water actually drips into the buckets rather than flowing. Under this condition, the bucket tips between drips, and no error water is added to a full moving bucket.

To Check Calibration

1. Obtain a plastic or metal container of at least one liter capacity. Make a very small hole (a pinhole) in the bottom of the container.
2. Place the container in the top funnel of the Rain Gauge. The pinhole should be positioned so that the water does not drip directly down the funnel orifice.
3. Follow the instructions for the Rain Gauge model you have:
 - **RG3:** Pour exactly 473 ml of water into the container. Each tip of the bucket represents 0.01 inch of rainfall.
 - **RG3-M:** Pour exactly 373 ml of water into the container. Each tip of the bucket represents 0.2 mm of rainfall.
4. If it takes less than one hour for this water to run out, then the hole (from step 1) is too large. Repeat the test with a smaller hole.
5. Successful field calibration of this sort should result in one hundred tips plus or minus two.
6. Adjusting screws are located on the outside bottom of the Rain Gauge housing. These two socket head set screws require a 5/64 inch Allen wrench. Turning the screws clockwise increases the number of tips per measured amount of water. Turning the screws counterclockwise decreases the number of tips per measured amount of water. A 1/4 turn on both screws either clockwise or counterclockwise increases or decreases the number of tips by approximately one tip. Adjust both screws equally; if you turn one a half turn, then turn the other a half turn.
7. Repeat Steps 3–6 as necessary until the Rain Gauge has been successfully calibrated.

DATA LOGGING RAIN GAUGE

RG3 and RG3-M

User's Manual



Table of Contents

Welcome	2
Specifications.....	2
Functional Overview	4
Accessing the Logger	4
Using the Logger for Temperature Measurement	5
Connecting the Logger to Computer	6
Logger Triggered Start	6
Internal Events.....	7
Logger Operation.....	7
Data Storage.....	7
Protecting the Logger	7
Battery	8
Mounting the Rain Gauge.....	9
Maintenance	11
Field Calibration.....	11

Welcome

Thank you and congratulations on your purchase of a Data Logging Rain Gauge from Onset Computer Corporation. With proper care, it will give you years of accurate and reliable measurements. Please be sure that you read and understand this manual before operating the Rain Gauge.

Contents of This Package

- Data Logging Rain Gauge, Onset Part No: RG3 or RG3-M
- Mounting Accessories: 2 Hose Clamps, 3 Screws
- This User's Manual

Additional Required Equipment

- Optic USB Base Station and Coupler, Onset Part No: BASE-U-1
- Onset HOBOWare[®] software version 2.1 or later

Specifications

Rain Gauge	
Maximum Rainfall Rate	12.7 cm (5 in.) per hour
Calibration Accuracy	±1.0% (up to 2 cm per hour for the RG3-M or up to 1 in. per hour for the RG3)
Resolution	0.2 mm (RG3-M) or 0.01 in. (RG3)
Calibration	Requires annual calibration: can be field calibrated or returned to the factory for re-calibration
Operating Temperature Range	0° to +50°C (+32° to +122°F)
Storage Temperature Range	-20° to +70°C (-4° to +158°F)
Environmental Rating	Weatherproof
Housing	15.24 cm (6 in.) aluminum bucket
Tipping Bucket Mechanism	Stainless steel shaft and bearings
Dimensions	25.72 cm height x 15.24 cm diameter (10.125 x 6 in.); 15.39 cm (6.06 in.) receiving orifice
Weight	1.2 Kg (2.5 lbs)
Part Numbers	RG3 (0.01 in. per tip) RG3-M (0.2 mm per tip)
	The CE Marking identifies this product as complying with all relevant directives in the European Union (EU).

3. Ensure that the pole or mast is vertical.
4. Top of rain gauge should be above top of pole.
5. Use the two supplied hose clamps to mount the rain gauge on pole or mast:
 - a. Open each hose clamp and place it around the pole.
 - b. Close the hose clamps until the rain gauge side bracket easily slides into the clamp.
 - c. Hold the rain gauge bracket against the pole with the top of the rain gauge above the top of the pole.
 - d. Slip the upper clamp over the side bracket and tighten the clamp until the rain gauge is secure. Note: Be sure the collector is above the top of the mast so you don't get any splashing, wind, shedding, or shadow effects.
 - e. Install the lower clamp.
 - f. Ensure that the top of the rain gauge is level and above the top of the pole.

Maintenance

Clean the filter screen, funnel, and tipping-bucket mechanism with mild soap and water and a cotton swab. To remove screen for cleaning, remove the spring clip from inside the collector. Clean the screen and funnel. Replace the screen and the spring clip. An accumulation of dirt, bugs, etc. on the tipping bucket will adversely affect the calibration. Oil the needle bearings with light oil on an annual basis. In harsh environments, it is recommended that you lubricate the needle bearings more frequently.

Field Calibration

The tipping-bucket mechanism is a simple and highly reliable device. Absolutely accurate rain gauge calibration can be obtained only with laboratory equipment, but an approximate field check can be easily done. The rain gauge must be calibrated with a controlled rate of flow of water through the tipping-bucket mechanism.

The maximum rainfall rate that the rain gauge smart sensor can accurately measure is one inch of rain per hour (36 seconds between bucket tips). Therefore, the rain gauge should be field calibrated using a water flow rate equivalent to, or less than, one inch of rain per hour (more than 36 seconds between bucket tips). If the flow rate is increased, a properly calibrated instrument will read low. Decreasing the rate of flow will not materially affect the calibration. The reason for this is obvious if the tipping bucket assembly is observed in operation. With water falling into one side of the tipping bucket, there comes a point when the mass of the water starts to tip the bucket. Some time is required for the bucket to tip (a few milliseconds). During the first 50% of this tipping time water continues to flow into the filled bucket; the last 50%

General Mounting Considerations

- The rain gauge housing **MUST** be mounted in a LEVEL position.
- A clear and unobstructed mounting location is necessary to obtain accurate rainfall readings. Tall objects can interfere with accurate rain measurements. It is recommended that you place the rain gauge away from the obstruction by a distance greater than three times the height of the obstruction. If that is not possible, raise the rain gauge as high as possible to avoid shedding.
- Avoid splashing and puddles. Be sure the gauge is high enough above any surface that rain will not splash into the top of the collector.
- Vibration can significantly degrade accuracy of the tipping bucket mechanism. In windy locations make sure that the bucket will be vibration-free.
- For maximum sensitivity in low-moisture environments you can remove the collector screen. This eliminates water retention on the screen which could evaporate before being measured. The tradeoff is that without the screen, debris can get into the funnel and clog the orifice. To remove the screen you need to first remove the spring clip inside the collector.

Horizontal Surface Mounting

If mounting the Rain Gauge on a horizontal surface (recommended):

1. The rain gauge housing **MUST** be mounted in a LEVEL position, clear of overhead structures, and in a location free from vibration.
2. Use the rain gauge as a template by placing the housing on the mounting surface and marking the holes for the three mounting 'feet.' **Note:** The three mounting holes are equally spaced on a 16.99 cm (6.688 in.) diameter circle.
3. For wood surfaces, drill three 0.16 cm (1/16 in.) diameter holes.
4. For concrete, drill three appropriately sized holes with a masonry bit, and install screw plug inserts.
5. Use shims as required to level the rain gauge.
6. Secure the rain gauge mounting feet with the three screws supplied with the rain gauge.

Pole or Mast Mounting

If mounting the Rain Gauge on a pole or mast:

1. The rain gauge housing **MUST** be mounted in a LEVEL position, clear of overhead structures, and in a location free from vibration.
2. Ensure that the pole or mast is properly guyed so that vibration in high winds is kept to a minimum.

Logger	
Time stamp Resolution	1.0 second
Time accuracy	± 1 minute per month at 25°C (77°F), see Plot B.
Operating range	-20° to 70°C (-4° to 158°F)
Environmental rating (for logger used outside of rain gauge)	Tested to NEMA 6 and IP67; suitable for deployment outdoors
NIST traceable certification	Available for temperature only at additional charge; temperature range -20° to 70°C (-4° to 158°F)
Battery	CR-2032 3V lithium battery; 1 year typical use
Memory	64K bytes – 16K to 23K when recording events only; 25K to 30K data points when recording events and temperature; see <i>Data storage</i> on page 7.
Materials	Polypropylene case; stainless steel screws; Buna-N o-ring; PVC cable insulation
CE	The CE Marking identifies this product as complying with all relevant directives in the European Union (EU).

Temperature Measurement

(see *Using the Logger for Temperature Measurement* on page 5)

Measurement range	-20° to 70°C (-4° to 158°F)
Accuracy	±0.54°C from 0° to 50°C (± 0.97°F from 32° to 122°F), see Plot A. A solar radiation shield is required for accurate temperature measurements in sunlight.
Resolution	0.10°C at 25°C (0.18°F at 77°F), see Plot A.
Drift	Less than 0.1°C/year (0.2°F/year)
Response time	Airflow of 1 m/s (2.2 mph): 10 minutes, typical to 90%

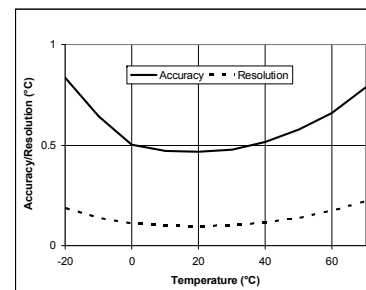

Plot A

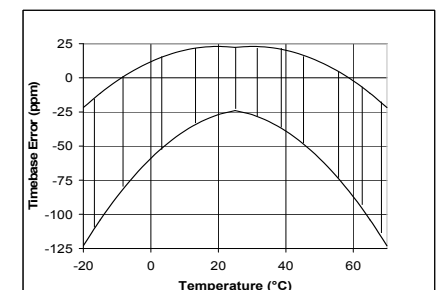

Plot B

Functional Overview

The Data Logging Rain Gauge consists of two major components: a **Tipping-Bucket Rainfall Collector**, and a **HOBO® Event/Temperature Data Logger**.

The collector consists of a black-anodized aluminum knife-edged ring, screen, and funnel assembly that diverts rainwater to a tipping-bucket mechanism located in an aluminum housing. The housing is coated with a white baked enamel surface designed to withstand years of exposure to the environment. The tipping-bucket mechanism is designed such that one tip of the bucket occurs for each 0.01" (RG3) or 0.2 mm (RG3-M) of rainfall. Each bucket tip is detected when a magnet attached to the tipping bucket actuates a magnetic switch as the bucket tips, thus effecting a momentary switch closure for each tip. The spent rainwater then drains out of the bottom of the housing. The switch is connected to a HOBO Event/Temperature data logger, which records the time of each tip.

The data logger is a rugged, weatherproof event logger with a 10-bit temperature sensor. It can record 16,000 or more measurements and tips. It uses a coupler and optical base station with USB interface for launching and data readout by a computer. Data shuttle options are also available.

Note: The HOBO Event/Temperature data logger and the Tipping-Bucket Collector each have their own serial number. The logger serial number is visible through the logger housing and is also recorded in the HOBOware data file (.hobo file). The Tipping-Bucket Collector serial number is found on both the collector housing product label and the packing box. Take a moment and record the serial numbers here:

HOBO Event/Temperature Data Logger Serial No: _____

Tipping-Bucket Collector Serial No: _____

Accessing the Logger

To access the logger, first remove the ring, screen, and funnel assembly by simply pulling up the ring while holding down the rain gauge housing. The logger can then be seen installed in its holder inside the rain gauge housing (see Figure 1).

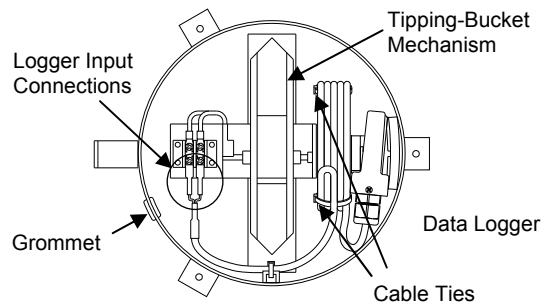

Figure 1: Rain Gauge Internal View
(ring, screen, and funnel assembly removed)

5. Return the circuit board, desiccant pack, and label to the case, carefully aligning the circuit board with the grooves in the case so that the battery faces the ridged side of the case.
6. Replace the end cap, ensuring that the o-ring is seated in the groove, and not pinched or twisted. Make sure no dirt or lint is trapped on the o-ring, as this could result in a leak.
7. Re-fasten the screws. Do not over-tighten the screws.

⚠ WARNING: Do not cut open, incinerate, heat above 85°C (185°F), or recharge the lithium battery. The battery may explode if the logger is exposed to extreme heat or conditions that could damage or destroy the battery case. Do not dispose of the logger or battery in fire. Do not expose the contents of the battery to water. Dispose of the battery according to local regulations for lithium batteries.

Mounting the Rain Gauge

The rain gauge has provisions for mounting two ways, surface mounting and pole mounting (see Figures 5 and 6). Surface mounting is recommended where possible. **Note:** Figure 6 has logger deployed outside of rain gauge housing, mounted inside an optional solar radiation shield.

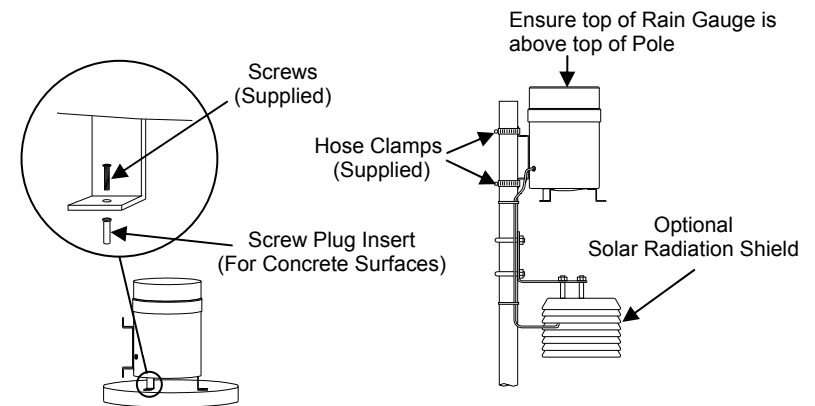

Figure 5: Surface Mounting

Figure 6: Pole or Mast Mounting

Notice! During shipment, the tipping assembly has been secured to avoid possible damage to the pivot assembly. Before installation, lift off the collector ring assembly (ring, screen, and funnel), and remove the rubber band inside the housing to release the tipping-bucket mechanism. After the rain gauge is installed, remove the collector ring assembly and verify that the tipping-bucket mechanism is not in the dead-center position. Press either end of the tipping bucket down against the stop to be sure that it is not centered.

If the logger is used in a humid location, periodically inspect the desiccant and dry it if it is not bright blue. To dry the desiccant, remove the desiccant pack and leave the pack in a warm, dry location until the bright blue color is restored. (Refer to the “Battery” section for instructions on removing and replacing the logger cap.)

Temperature range	Desiccant maintenance schedule
Less than 30°C (86°F)	Approximately once per year
30° to 40°C (86° to 104°F)	Approximately every six months
Over 40°C (104°F)	Approximately every three months

Note! Static electricity may cause the logger to stop logging. To avoid electrostatic discharge, transport the logger in the rain gauge housing or in an anti-static bag, and ground yourself by touching an unpainted metal surface before handling the logger. For more information about electrostatic discharge, visit <http://www.onsetcomp.com/support/support.html>.

Battery

The logger requires one 3-Volt CR-2032 lithium battery. Battery life varies based on the temperature and the frequency at which the logger is recording data (the logging interval). A new battery typically lasts one year with logging intervals greater than one minute or if used for rainfall logging only. Deployments in extremely cold or hot temperatures, or logging intervals faster than one minute, may significantly reduce battery life. Continuous logging at the fastest logging rate of one second will deplete the battery in as little as two weeks. To replace the battery:

1. See Figure 4. Remove the two screws that secure the end cap to the case and remove the cap. The circuit board is attached to the cap.

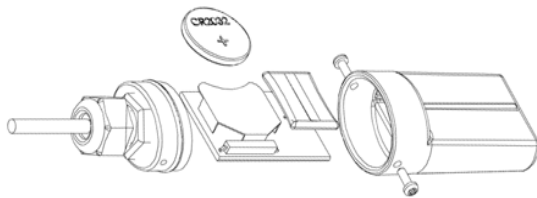

Figure 4: Battery Replacement

2. Examine the desiccant pack that is tucked below the battery holder. If the desiccant is not bright blue, put the desiccant pack in a warm, dry place until the blue color is restored.
3. Carefully push the battery out of the holder with a small, nonmetallic blunt instrument.
4. Insert a new battery, positive (+) side facing up.

Logger-to-Rain Gauge Connection

The logger’s black and white input wires are connected to the tipping-bucket output by a terminal block as shown in Figure 1.

Logger Deployment Considerations

Ensure logger cable does not interfere with the operation of the tipping bucket mechanism! When logger is not deployed outside of the rain gauge housing, cable should be neatly coiled with no sharp bends, secured with cable ties, and placed between tipping bucket holder and logger holder (see Figure 1). Logger should be placed securely in its holder.

Using the Logger for Temperature Measurement

To use the logger to record temperature, it must be deployed outside of the rain gauge housing in a suitable solar radiation shield (such as those supplied by Onset) to ensure accurate temperature measurements.

1. If not already done, lift off the ring, screen, and funnel assembly and then *carefully* cut any cable ties that secure the cable.
2. Unscrew the two terminal block screws that secure the logger’s black and white input wires. **Note:** Screws do not have to be completely removed—only enough to slide out the two spade terminals.
3. Remove logger and cable from housing.
4. From outside of housing, feed the spade terminal end of cable through the rubber grommet and reconnect to terminal block. The polarity of the input connection is not important. **Make sure any excess cable inside of housing is secured so that it does not interfere with the operation of the tipping bucket mechanism!** If possible, create service loop for cable by using two small cable ties to loop and secure cable to cable tie mount (see Figure 2).

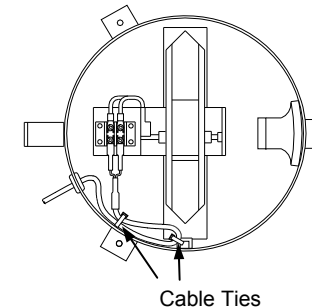

Figure 2: Service Loop

Connecting the Logger to Computer

The HOBO Event/Temperature data logger requires an Onset-supplied Optic USB Base Station and Coupler (part no: BASE-U-1), and HOBOWare version 2.1 or later software to connect to computer. If possible, avoid connecting at temperatures below 0°C (32°F) or above 50°C (122°F).

1. Plug the USB connector on the base station into an available USB port on your computer.
2. Insert the logger and the base station into the coupler, as shown in Figure 3. Make sure that the logger is inserted in the end of the coupler that has the magnet, and that the ridges on the base station and logger are aligned with the grooves in the coupler.

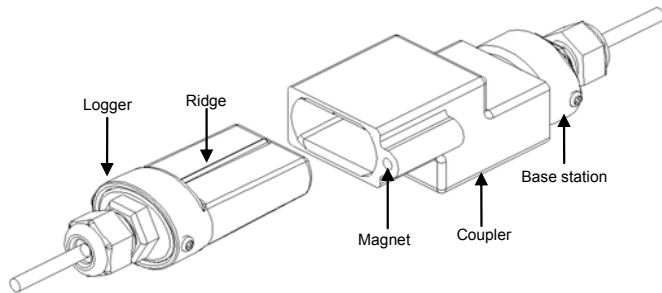

Figure 3: Inserting Logger into Base Station

3. If the logger has never been connected to the computer before, it may take a few seconds for the new hardware to be detected.
4. Use the logger software to launch and read out the logger.

Note: You can read out the logger or check its status while it continues to log, stop it manually with the software, or let it record data until the memory is full. Refer to the software user's guide for complete details on launching, reading out, and viewing data from the logger.

Logger Triggered Start

The logger can be configured to start logging at your command using the magnet in the coupler or any strong magnet to trigger the start.

1. Use the logger software to launch the logger with *Trigger Start* selected for the Default Launch Type. Remove the logger from the coupler.
2. Bring the logger and the empty coupler, or strong magnet, to the deployment location.

Important: Any magnet can trigger a start. This can be helpful, but it can also cause a premature start. Keep the logger away from strong magnetic fields until you are ready to begin logging.

3. When you are ready for the logger to start logging, insert the logger into the empty coupler (or place it next to a strong magnet) and remove it after three seconds. **Important: The logger will not launch if the coupler is attached to a base station.**
4. Verify that the logger's light is blinking at least every four seconds.

Internal Events

Like other U-Series loggers, this logger stores internal events that are unrelated to the external event input. Internal events are stored when the coupler is attached or detached, when the battery drops below approximately 2.7V, when the battery rises above 2.8V, when a host computer is connected, and when the logger is stopped by a command from the host software.

Logger Operation

A light (LED) on the front of the logger confirms logger operation. The following table explains when the light blinks during logger operation.

When:	The light:
The logger is logging	Blinks once every one to four seconds (the shorter the logging interval, the faster the light blinks); blinks when logging a sample
The logger is awaiting a start because it was launched in Start At Interval, Delayed Start, or Trigger Start mode	Blinks once every eight seconds until logging begins

Data Storage

The data logger has 64,000 bytes of nonvolatile data storage. The logger records a time stamp for each tipping-bucket tip. Data storage requirements per tip are a function of enabled channels and logging interval. When tips are three to 12 days apart, 32 bits are required to record a single tip (16,000 tips). When tips are less than 16 seconds apart, only 22 bits are required to record a single tip (23,000 tips). In most cases, 25,000 to 30,000 data points (including tips, temperature, and/or battery measurements) can be logged. For most rain gauge applications, battery life, not memory capacity, will be the factor that limits deployment duration.

Protecting the Logger

Do not store the logger in the coupler. Remove the logger from the coupler when you are not using it. When the logger is in the coupler or near a magnet, it consumes more power and will drain the battery prematurely.

Keep the logger away from magnets. Being near a magnet can cause false coupler events to be logged. It can also launch the logger prematurely if it was waiting for a trigger start.