



**MANUAL**  
**SURFACE ROUGHNESS TESTER**  
**TR-200**

**PARTNERS IN PRECISION**



## CONTENTS

<b>1</b>	<b>Overview</b>	<b>5</b>
1.1	Measurement principles	5
1.2	Standard configuration	6
1.3	Names of each part of the instrument	6
1.4	Basic connection method	7
1.4.1	Installation and unloading of sensor	7
1.4.2	Power adapter and charging of battery	8
<b>2</b>	<b>Measuring operation</b>	<b>9</b>
2.1	Preparation for measurement	9
2.2	Basic measurement status	10
2.3	Modifying conditions of measurement	13
2.3.1	Sampling length	13
2.3.2	Evaluation length	13
2.3.3	Standard	14
2.3.4	Stroke	14
2.3.5	Filter	15
2.3.6	Parameter	15
2.4	System setup	16
2.4.1	Language	16
2.4.2	Unit	16
2.4.3	Display	17
2.5	Function selection	18
2.5.1	Printing	18
2.5.2	Non-filtered profile	19
2.5.3	Position of probe	20
2.5.4	Display value calibration	20
2.6	Communication with pc	21
<b>3</b>	<b>Options and usage</b>	<b>22</b>
3.1	Adjustable leg and sheath of sensor	22
3.2	Measurement platform	23
3.3	Extension rod	23
3.4	Connection rod of magnetic gauge base	24
3.5	Side transformation rod	24
3.6	Curved surface sensor	25

<b>4</b>	<b>Technical parameter and features</b>	<b>26</b>
4.1	Sensor	26
4.2	Driving parameter	26
4.3	Error of displayed value	26
4.4	Fluctuation of displayed value	26
4.5	Display content	26
4.6	Profile and filter	27
4.7	Cut off length/sampling length	27
4.8	Evaluation length	27
4.9	Roughness parameter and display range	28
4.10	Measurement range and resolution	28
4.11	Power supply	28
4.12	Temperature/humidity range	28
4.13	Dimension and weight	29
4.14	Connect with pc	29
4.15	Connect with printer	29
<b>5</b>	<b>General maintenance</b>	<b>30</b>
5.1	Trouble shooting	30
5.2	Fault information	30
<b>6</b>	<b>Reset</b>	<b>31</b>
<b>7</b>	<b>References</b>	<b>32</b>
7.1	Profile and filter	32
7.1.1	Profile	32
7.1.2	Filter	32
7.2	Central line	32
7.3	Length of driving stroke	32
7.3.1	RC filter	32
7.3.2	PC-RC filter	32
7.3.3	Gauss filter	33
7.3.4	D-P Direct profile	33
7.4	Definition of TR-200 roughness parameters	33
7.4.1	Ra arithmetical mean deviation of profile	33
7.4.2	Rq root-mean-square deviation of profile	34
7.4.3	Rz ten point height of irregularities	34
7.4.4	Ry (ISO) maximum height of profile	34
7.4.5	Ry (DIN) maximum height of profile	35
7.4.6	Rt total peak-to-valley height	35

7.4.7	Rp maximum depth of profile peak	35
7.4.8	Rm maximum depth of profile valley	35
7.4.9	Sm mean spacing of profile irregularities	35
7.4.10	S mean spacing of local peaks of profile	36
7.4.11	tp profile bearing length ratio	36
7.4.12	Sk skewness of the profile	36
7.4.13	R3z third maximum peak-to-valley height	37



Start key 

Parameter key 

Esc key 

Menu key 

Scroll key 

"Enter" key 

Power key 

# 1 OVERVIEW

TR-200 portable roughness instrument is manufactured and developed by Time Group. This instrument applies to production site and can be used to measure surface roughnesses of various machinery-processed parts, calculate corresponding parameters according to selected measuring conditions and clearly display all measurement parameters and profile graphs on LCD.

Features:

- Multiple parameter measurement:  
Ra, Rz, Ry, Rq, Rp, Rm, Rt, R3z, Rmax, Sk, S, Sm, tp;
- Highly sophisticated inductance sensor;
- Four wave filtering methods of RC, PC-RC, GAUSS and D-P;
- Compatible with four standards of ISO, DIN, ANSI and JIS;
- 128×64 lattice LCD displays all parameters and graphs;
- DSP chip is used to control and process data with high speed and low power consumption;
- Built-in lithium ion chargeable battery and control circuit with high capacity, without memory effect. The consecutive work time is longer than 20 hours;
- Design of mechanical and electrical integration is adopted to achieve small bulk, light weight and easy usage;
- Can be connected to Time TA220s printer to print all parameters and graphs;
- Standard built-in RS232 interface enables communication with PC;
- Automatic switch off, memory and various prompt instructions;
- Optional accessories such as curved surface sensor, measurement platform, sheath of sensor, adjustable leg, stretchable pole and side transform pole are available.

## 1.1 MEASUREMENT PRINCIPLE

When measuring the roughness of a surface, the sensor is placed on the surface and then uniformly slides along the surface by driving the mechanism inside the instrument. The sensor gets the surface roughness by the sharp built-in probe. This roughness causes displacement of the probe which results in change of inductive amount of induction coils so as to generate analogue signal, which is in proportion to the surface roughness at output end of phase-sensitive rectifier. After amplification and level conversion this signal enters the data collection system. After that, those collected data are processed with digital filtering and parameter calculation by the DSP chip. The measurement results can be read on LCD, printed through the printer and communicated with PC.

## 1.2 STANDARD CONFIGURATION

Table 1-1

*Standard Configuration List*

Name	Amount
Standard sensor	one
Main processor	one set
Standard sample plate	one
Power adapter	one
RS232 communication cable	one

## 1.3 NAMES OF EACH PART OF THE INSTRUMENT

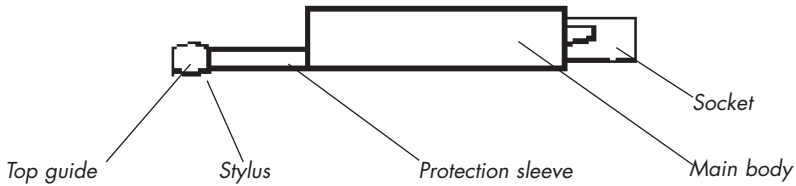

Figure 1-1-1 Sensor

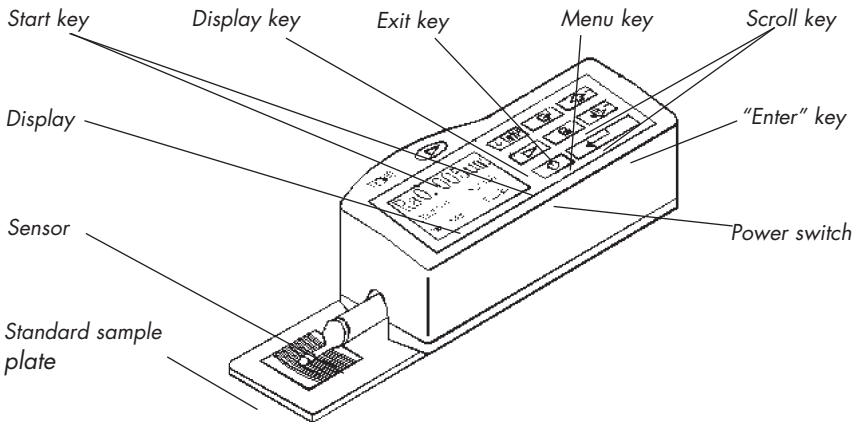

Figure 1-1-2 Front View of Instrument

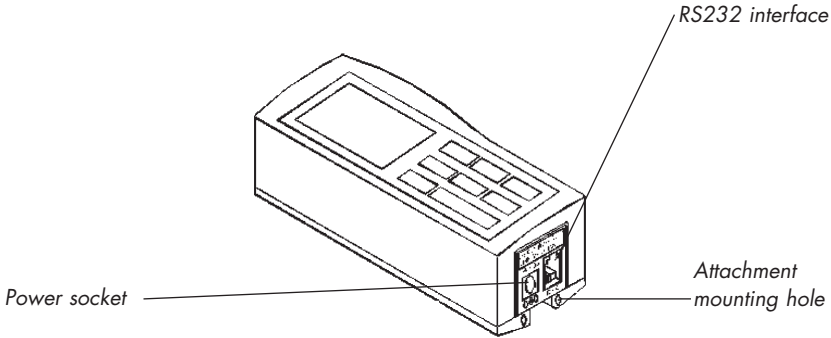

Figure 1-1-3 Side View of Instrument

## 1.4 BASIC CONNECTION METHOD

### 1.4.1 Installation and Unloading of Sensor

To instal, hold the main part of the sensor by hand, push it into connection sheath at the bottom of the instrument as shown in Figure 1-2 and then slightly push to the end of sheath. To unload, hold the main part of sensor or the root of protective sheath and slowly pull it out.

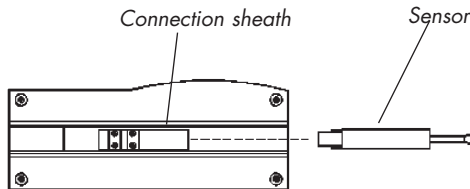

Figure 1-2 Installation and Unloading of Sensor

Tip:

1. The probe of the sensor is the main part of this instrument and requires close attention
2. During installation and unloading, the probe should not be touched in order to avoid damage which can affect measurement results.
3. Connection of the sensor should be reliable during installation.



### 1.4.2 Power Adapter and Charging of Battery

When the battery voltage is too low (which is indicated by the battery symbol flashing on the screen), the instrument should be charged as soon as possible. Follow the indications shown in Figure 1-3: the power adapter should be plugged into the power socket of the instrument. The power adapter should be connected to 220V 50Hz and charging of the battery will begin. Input voltage for power adapter is AC 220V with DC 6V of output, about 500mA of maximum charge current, charging time of up to 2.5 hours. This instrument uses a lithium ion chargeable battery. Charging can be fulfilled at any time without affecting the normal operation of the instrument.

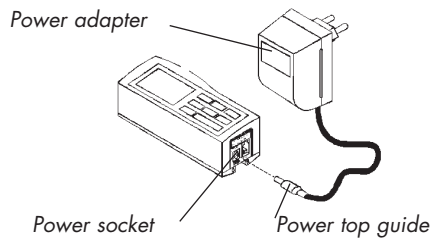





Figure 1-3 Connection of Power Adapter

#### Tip:

1. Layout of connection lines will not affect measuring part while charging.
2. The meanings of battery indicators are:
  -  indicates normal voltage and measurement can be carried out; the black part inside prompt shows capacity of battery;
  -  indicates too-low voltage and battery should be charged as soon as possible;
  -  indicates that battery is being charged;
  -  indicates that battery is full and power should be cut off as soon as possible;
3. Relative high noises of the power source can affect measurement to weak signal to some extent when battery is being charged;
4. The instrument needs to monitor the process of charging so that it is not necessary to turn it off. The instrument will turn on automatically even when switched off.

## 2 MEASURING OPERATION

### 2.1 PREPARATION FOR MEASUREMENT

- Switch on to test if the battery voltage is normal;
- Clear the surface of the part to be measured;
- Refer to Figure 2-1 and Figure 2-2 to place the instrument correctly, stable and reliably on the surface to be measured;

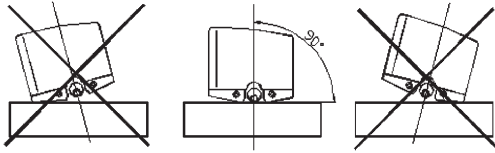

Figure 2-1 Front View

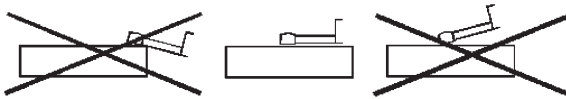

Figure 2-2 Side View

- Refer to Figure 2-3: the sliding trail of the sensor must be vertical to the direction of process line of the measured surface.

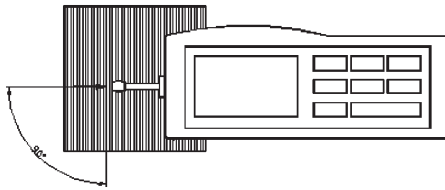



Figure 2-3 Measuring Direction

#### **Instruction:**

Correct and standard operation is required for accurate measurement results, please make sure to follow our manual's instructions.

## 2.2 BASIC MEASUREMENT STATUS

Press Power key  to switch on. The instrument automatically displays the model, name and information of the manufacturer, and then enters the basic measurement status, as shown in Figure 2-4.

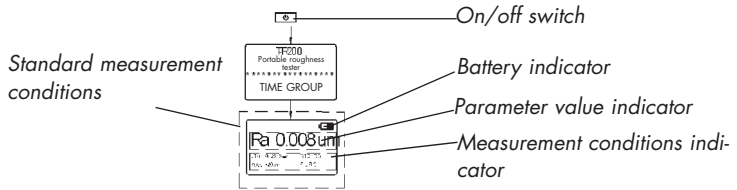

Figure 2-4 Switch-on Process

### Instruction:

The contents of the basic measurement status entered in the first switch-on (or after reset) are default settings of this instrument. Settings of the last switch-off will be displayed in the next switch-on. The basic measurement status will be entered automatically for each switch-on (as shown in Figure 2-4).

In basic measurement status, perform as follows:

- Measurement

Press Start key  to start measurement · as shown in Figure 2-5.

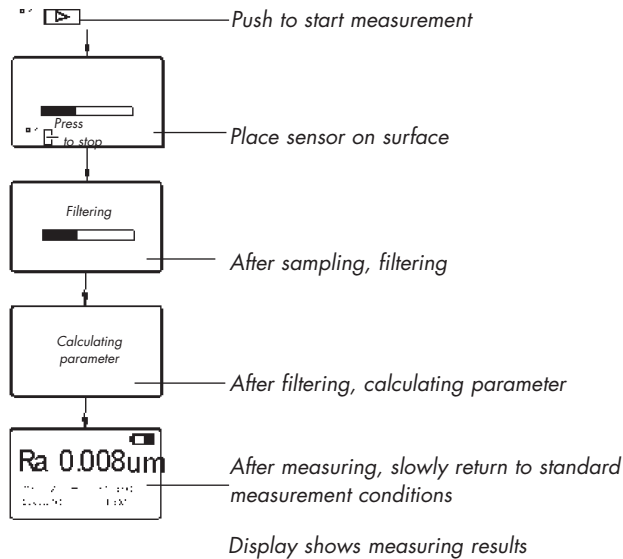





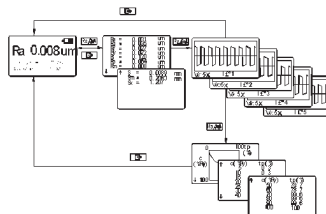

Figure 2-5 Measurement Process

- Enter menu operation  
Press Menu key  to enter menu operation .  
For detailed operation, see descriptions in the corresponding chapters and sections below.
- Display measurement parameters  
When pressing the Parameter key  for the first time, the display shows all parameter values of this measurement, press Scroll key   to scroll up and down. When pressing the Parameter key for the second time, the display shows the profile figure of this measurement, press the Scroll key to roll profile figures with other sampling lengths. When pressing the Parameter key for the third time, the display shows the tp figure and tp value of this measurement; pressing keys again will repeat above descriptions. Press  Esc key in each status to return to the begin status (as shown in figure below). 



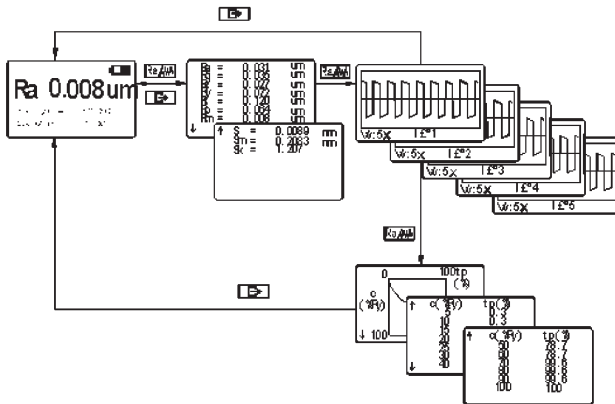

Figure 2-6 Display of Parameters

- Display position of probe  
Press Enter key to show the position of probe in shortcut mode, which is easy to use in practical measurement.

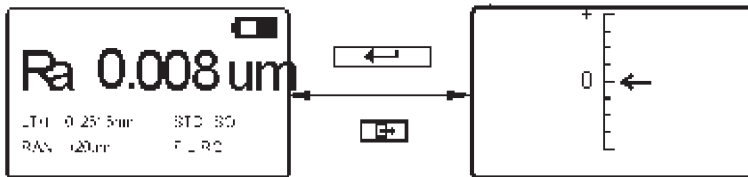

Figure 2-7 Position of Probe

**Instructions:**

1. The instrument automatically stores results and conditions of the last measurement before it is turned off, and will automatically enter this status when it is turned on again.
2. After entering the begin status, press Start key to measure if measuring conditions are not to be changed.
3. If the position of the probe is close to the limit of stroke or beyond it, slightly adjust the position of the sensor . Please follow the instructions of 2.1 Preparation for Measurement.

## 2.3 MODIFYING CONDITIONS OF MEASUREMENT

Under basic measurement status, press Menu key to enter menu operation. Use the Scroll key to select setting function of measured conditions, and then press the Enter key. Set Measurement Conditions . In this status, all measurement conditions can be modified (as shown in Figure 2-8).

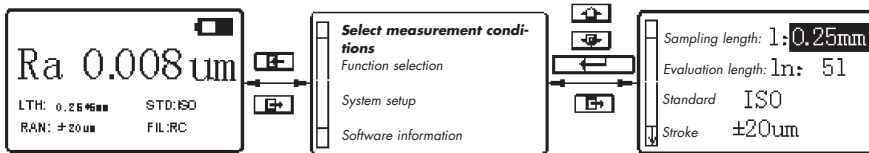

Figure 2-8 Select Set Measurement Conditions Status

### 2.3.1 Sampling Length

After entering the settings, use the Scroll key to select Set Sampling Length. Press Enter key to cycle between 0.8 mm → 2.5mm → auto → 0.25mm (as shown in Figure 2-8). Stop at the value you need and use the Scroll key to modify the others.

### 2.3.2 Evaluation Length

Press Menu key to enter menu operation and use the Scroll key to select Set Measurement Conditions. Press Enter key to enter Set Measurement and use the Scroll key to select Set Evaluation Length. Press Enter key to cycle between 1|→2|→3|→4|→5|, which stands for 1~5 sampling lengths in evaluation length. (as shown in Figure 2-9).

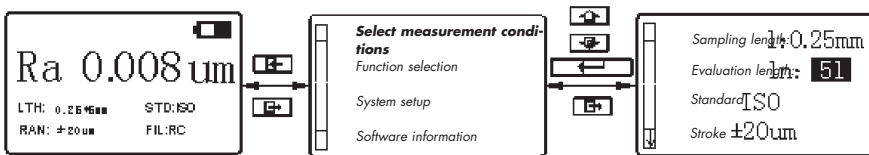

Figure 2-9 Modifying Evaluation Length

#### Instruction:

When the sampling length is set to be automatic, the evaluation length will automatically display value 5| to match. This value cannot be modified.

### 2.3.3 Standard

Press Menu key to enter menu operation and use the Scroll key to select Set Measurement Condition. Press the Enter key for measurement setting and use the Scroll key to select Set Standard. Press Enter key to choose between ISO → DIN → JIS → ANSI.

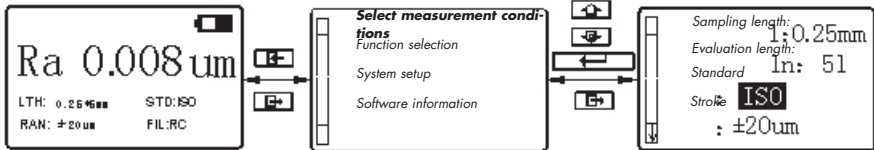

Figure 2-10 Modifying Standard

Table 2 Standard Code and Name

Code	Standard Name
ISO 4287	International Standard
DIN 4768	German Standard
JIS B601	Japanese Industrial Standard
ANSI B46.1	American Standard

### 2.3.4 Stroke

Press Menu key to enter menu operation status and use the Scroll key to select Set Measurement Conditions. Press Enter for measurement settings and use the Scroll key to select Set Stroke. Press Enter to cycle between  $\pm 20\mu\text{m}$  →  $\pm 40\mu\text{m}$  →  $\pm 80\mu\text{m}$  → auto

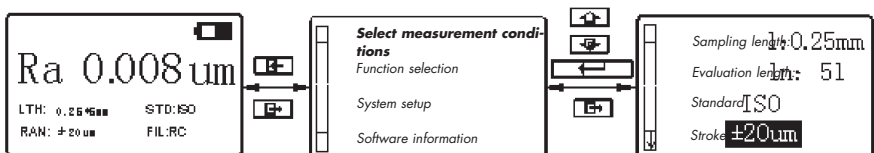

Figure 2-11 Modifying Stroke

### 2.3.5 Filter

Press Menu key to enter menu operation and use the Scroll key to select Set Measurement Conditions. Press Enter for measurement settings and use the Scroll key to select Set Filter. Press Enter to cycle between RC→PC-RC→Gauss→D-P.

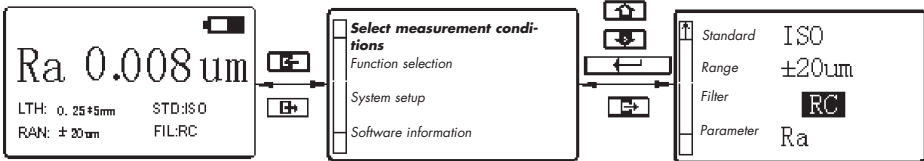

Figure 2-12 Modifying Filter

### 2.3.6 Parameter

Press Menu key to enter menu operation and use the Scroll key to select Set Measurement Conditions. Press Enter for measurement settings and use the Scroll key to select Parameter. Press Enter to cycle between Ra→Rz→Ry→Rq (of which: five parameters of Ra, Rz, Ry, Rmax, Rq are available for ANSI[American Standard] and DIN[German Standard]). After confirmation, the parameters selected will be displayed in the basic measurement status.

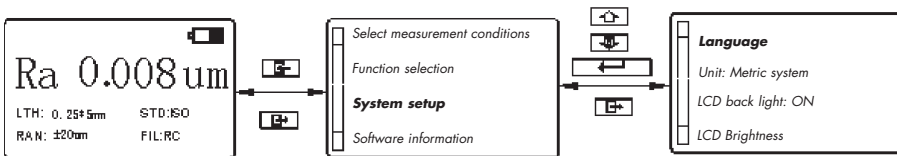

Figure 2-13 Modifying Parameters to Display



## 2.4 SYSTEM SETUP

Press Menu key to enter menu operation and use the Scroll key to select System Setup. Press Enter for system settings. In System Setup (as shown in Figure 2-14), you can modify the contents of system settings.

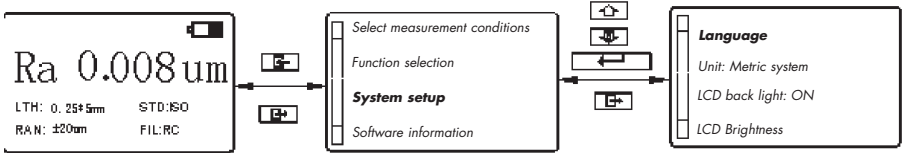

Figure 2-14 Select System Setup Function

### 2.4.1 Language

Press Menu key to enter menu operation and use the Scroll key to select System Setup. Press Enter for system settings and use the Scroll key to select Language. Press Enter for language selection and choose the language you need. Press Enter to confirm.

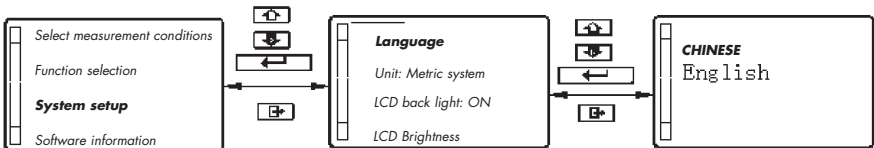

Figure 2-15 Language Selection Function

### 2.4.2 Unit

Press Menu key to enter menu operation and use the Scroll key to select System Setup. Press Enter for system settings and use the Scroll key to choose the unit. Press Enter to switch between the metric system and the British system.

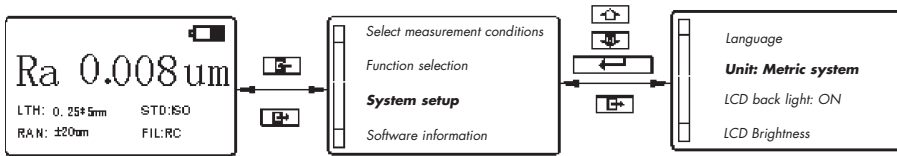

Figure 2-16 Metric/British System Switching Function

## 2.4.3 Display

### a. LCD Back Light

Press Menu key to enter menu operation and use the Scroll key to select System Setup. Press Enter for system settings and use the Scroll key to select LCD Back Light On/Off. Press Enter to switch between On and Off.

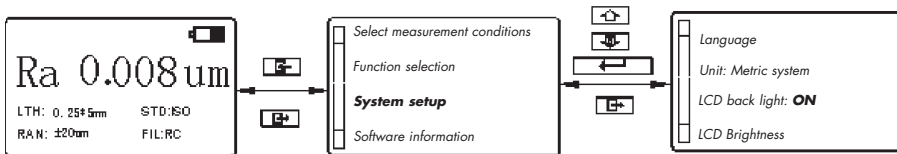

Figure 2-17 Back Light On/Off Function

### Instruction:

Press and hold On/Off key for 2 seconds to turn the back light on.

### b. LCD Brightness

Press Menu key to enter menu operation and use the Scroll key to select System Setup. Press Enter key for system settings and use Scroll key for LCD Brightness Adjustment. Press Enter key to enter LCD Brightness Adjustment and press Scroll key to adjust the brightness to a satisfying degree.

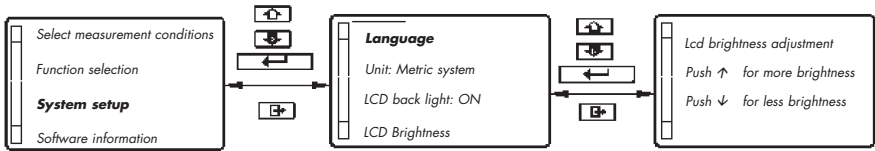

Figure 2-18 LCD Brightness Adjustment Function

## 2.5 FUNCTION SELECTION

Press Menu key to enter menu operation and use the Scroll key to select Function Selection. Press Enter to enter Function Selection. After that, select the functions you want.

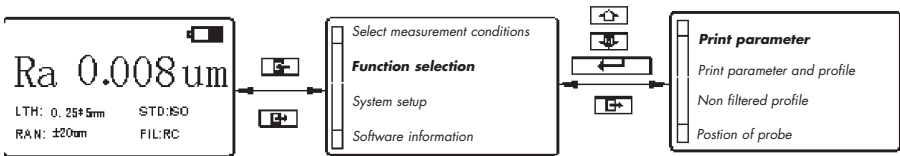

Figure 2-19 Choose Function Selection

### 2.5.1 Printing

Before printing, connect the instrument to the printer with the communication cable as shown in Figure 2-20, and set the printer to the On-Line status.

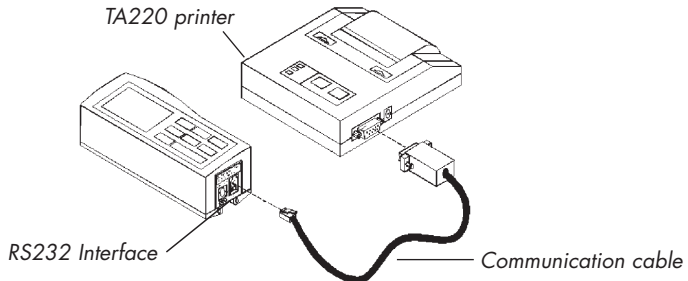

Figure 2-20 Connect Printer

### Instruction:

This instrument can be used with Time TA-series printers only. TA210 only prints values of measurement parameters. TA220s prints values of measurement parameters, profile figures and tp curve.

#### a. Print Parameters

Press Menu key to enter menu operation and use the Scroll key to choose Function Selection. Press Enter key to enter Function Selection and use the Scroll key to select Print Parameter. Press Enter to print all measurement parameters (as shown in Figure 2-19).

Instruction:

**Under basic measurement, press key to print all parameter values.**

#### b. Print Parameters and Profile

Press Menu key to enter menu operation and use the Scroll key to choose Function Selection. Press Enter for Function Selection and use the Scroll key to select Print Parameter and Profile. Press Enter to start printing.

The contents to print include all measurement parameters, profile figures after filtering and tp figure.

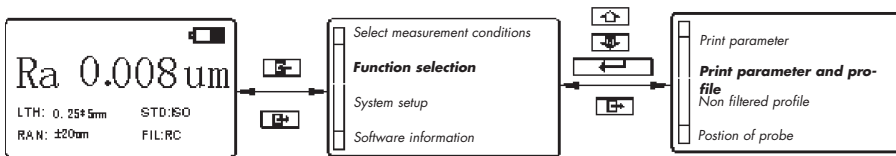

Figure 2-21 Choose Print Parameter and Profile Function

### 2.5.2 Non-Filtered Profile

Press Menu key to enter menu operation and use the Scroll key to choose Function Selection. Press Enter for Function Selection and use the Scroll key to select Non-Filtered Profile. Press Enter to display Non-filtered Profile (i.e. Direct Profile or Original Profile) in this measurement on LCD.

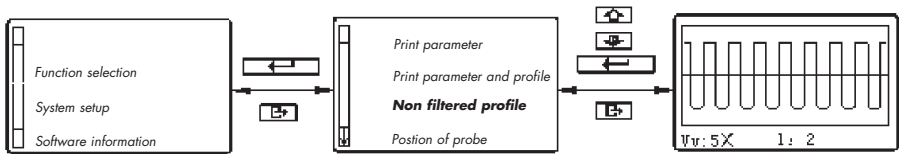

Figure 2-22 Select Non-Filtered Profile Function

### 2.5.3 Position of Probe

Press Menu key to enter menu operation and use the Scroll key to choose Function Selection. Press Enter for Function Selection and use the Scroll key to select the Position of Probe. Press Enter to display the position of probe.

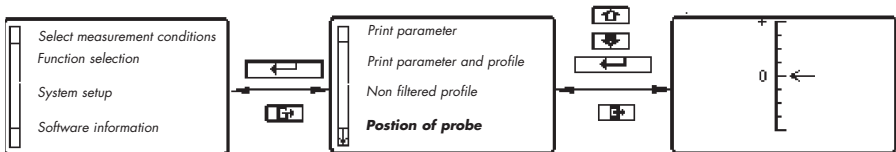

Figure 2-23 Select Display Position of Probe Function

### 2.5.4 Display Calibration Values

Press Menu key to enter menu operation and use the Scroll key to choose Function Selection. Press Enter for Function Selection and press Scroll key to select the Display Calibration Values function. Press Enter for Display Calibration Values and use the Scroll key to change the calibration coefficients. Press Enter to move the cursor.

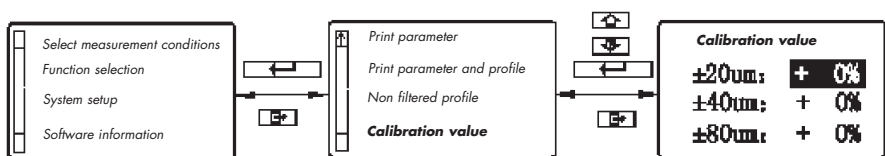

Figure 2-24 Select Display Value Calibration Function

**Instruction:**

1. While using the correct measuring method to test a random sampling plate, and the measured value exceeds  $\pm 10\%$  of the denominated value of sampling the plate, use Display Value Calibration function to calibrate according to the percentage of real deviation with a calibration range within  $\pm 20\%$ .
2. The instrument has been thoroughly tested before delivery to ensure that the display value error is less than  $\pm 10\%$ . The user is recommended not to use the Display Calibration Values function too often.

## 2.6 COMMUNICATION WITH PC

Before communicating with a PC, connect the instrument to the serial interface of the PC with communication cables attached to the instrument as shown in Figure 2-25, and enter private operation software Data View on PC.

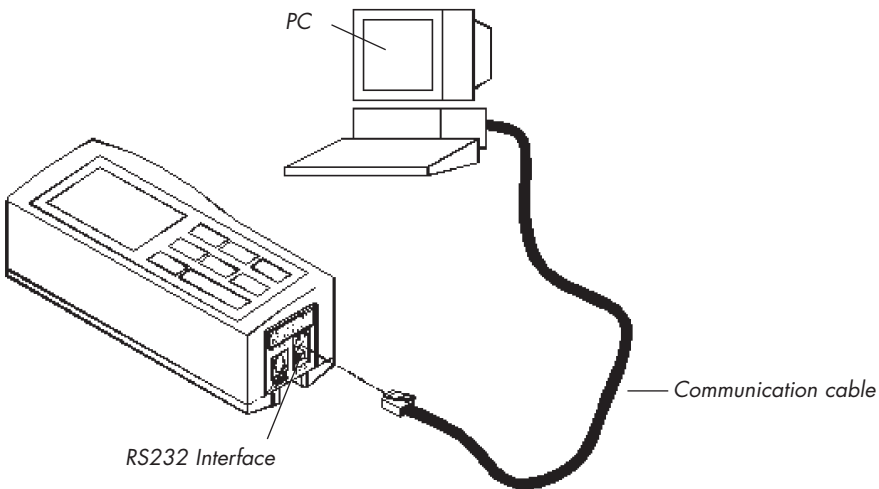

Figure 2-25 Connect PC

**Instruction:**

To establish the communication between this instrument and the PC, use Time Data View private software. Please see the Software Instructions for operation.

### 3 OPTIONS AND USAGE

#### 3.1 ADJUSTABLE LEG AND SHEATH OF SENSOR

When the measured surface of the part is smaller than the bottom surface of the instrument, the sheath of sensor and adjustable leg (TR-200 optional accessories) can be used for auxiliary support to complete measurement (as shown in Figure 3-1 and 3-2).

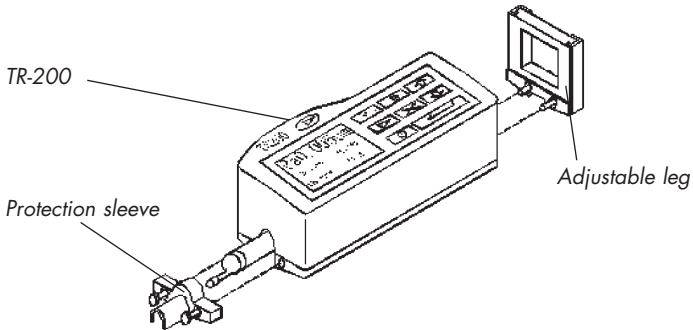

Figure 3-1 Connections of Adjustable Leg and Sheath of Sensor

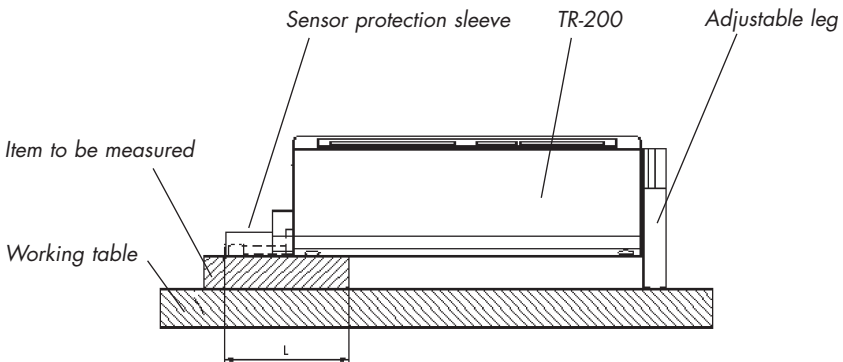

Figure 3-2 Usage of Adjustable Leg and Sheath of Sensor

**Tip:**

1. The above shall not be shorter than the driving stroke of this measurement to prevent the sensor from dropping out during measurement.
2. The locking of the adjustable leg has to be reliable.

### 3.2 MEASUREMENT PLATFORM

TA series measurement platforms can easily adjust positions between the instrument and the measured part with a flexible and stable operation and a wider application range. Roughness of complex shapes can also be measured. The TA series measurement platforms enable adjustment of the position of the probe to be more precise. If the Ra value of the measured surface is relatively low it is recommended to use a measurement platform.

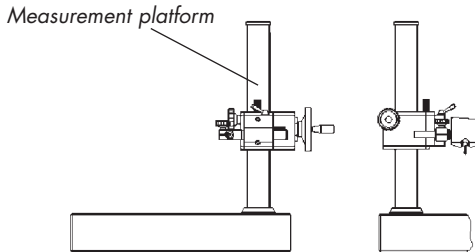

Figure 3-3 Measurement Platform

### 3.3 EXTENSION ROD

The extension rod increases the depth of the sensor to enter the part. The length of the extending rod is 50mm.

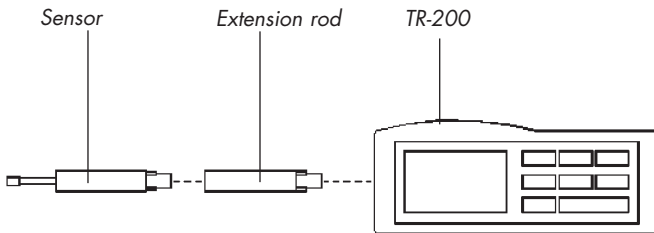

Figure 3-4 Extension Rod



### 3.4 CONNECTION ROD OF MAGNETIC GAUGE BASE

The connection rod connects the instrument with the magnetic gauge base to easily measure various surfaces as shown in figure 3-5. It is particularly suitable for production sites.

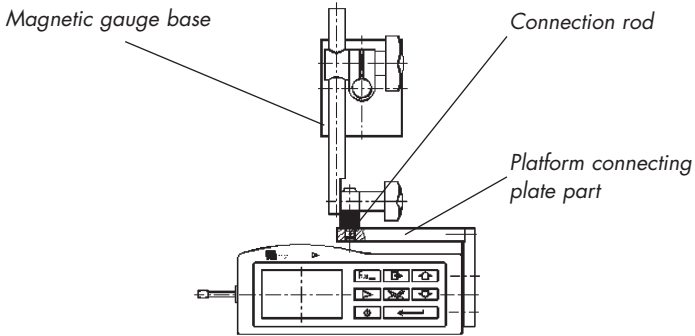

Figure 3-5 Connection of the Measurement Platform with Magnetic Gauge Base

### 3.5 SIDE TRANSFORMATION ROD

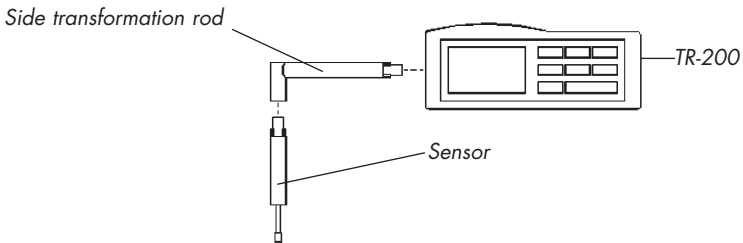

Figure 3-6 Side Transformation Rod Connection

The side transformation rod can be used to measure such parts as crankshaft.

### 3.6 CURVED SURFACE SENSOR

The curved surface sensor can measure convex or concave surfaces, as shown in figure below.

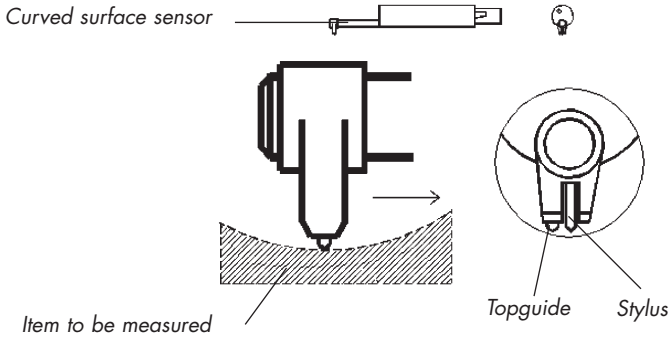

Figure 3-7 Curved Surface Sensor

## 4 TECHNICAL PARAMETER AND FEATURES

### 4.1 SENSOR

Test Principle:	Inductance type
Measurement Range:	160 $\mu$ m
Radius of Probe Pin:	5 $\mu$ m
Material of Probe Pin:	Diamond
Dynamo-measurement of Probe:	4mN(0.4gf)
Probe Angle:	90°
Vertical Radius of Guiding Head:	45mm

### 4.2 DRIVING PARAMETER

Maximum driving stroke:	17.5mm/0.7inch
Driving speed: measuring sampling length	= 0.25mm
	Vt=0.135mm/s
sampling length = 0.8mm	Vt=0.5mm/s
sampling length = 2.5mm	Vt=1mm/s
returning	V=1mm/s

### 4.3 ERROR OF DISPLAYED VALUE

Not more than  $\pm 10\%$

### 4.4 FLUCTUATION OF DISPLAYED VALUE

Not more than 6%

### 4.5 DISPLAY CONTENT

#### 4.5.1 Menu:

modify measurement conditions, calibration display value, select communication with PC or printing.

#### 4.5.2 Parameter:

parameters of roughness compatible with four standards of ISO, DIN, ANSI and JIS.

#### 4.5.3 Graph:

non-filtered profile figures, filtered profile figures and tp figure.

#### 4.5.4 Prompt information:

measurement, menu prompt, errors, battery capacity and switch-off prompt information.

### 4.6 PROFILE AND FILTER

Table 3

Profile	Filter
Filtered Profile	RC
Filtered Profile	PC-RC
Filtered Profile	Gauss
Non-Filtered Profile	D-P

### 4.7 CUT-OFF LENGTH/SAMPLING LENGTH

Automatic, 0.25mm, 0.8mm, 2.5mm (optional)

### 4.8 EVALUATION LENGTH

(1~ 5) | optional

## 4.9 ROUGHNESS PARAMETER AND DISPLAY RANGE

Table 4

Parameter	Display Range
Ra	0.005 $\mu$ m ~ 40 $\mu$ m
Rq	0.005 $\mu$ m ~ 40 $\mu$ m
Rz	0.02 $\mu$ m ~ 160 $\mu$ m
R3z	0.02 $\mu$ m ~ 160 $\mu$ m
Ry	0.02 $\mu$ m ~ 160 $\mu$ m
Rt	0.02 $\mu$ m ~ 160 $\mu$ m
Rp	0.02 $\mu$ m ~ 160 $\mu$ m
Rm	0.02 $\mu$ m ~ 160 $\mu$ m
Sk	0 ~ 100%
S	1mm
Sm	1mm
tp	0 ~ 100%

## 4.10 MEASUREMENT RANGE AND RESOLUTION

Table 5

Measurement Range	Resolution
Automatic	0.01 $\mu$ m ~0.04 $\mu$ m
$\pm 20\mu$ m	0.01 $\mu$ m
$\pm 40\mu$ m	0.02 $\mu$ m
$\pm 80\mu$ m	0.04 $\mu$ m

## 4.11 POWER SUPPLY

1 piece of lithium ion rechargeable battery

## 4.12 TEMPERATURE/HUMIDITY RANGE

### Working environment:

Temperature: 0 ~ 400C

Humidity: < 90% RH

### Store and transportation:

Temperature: - 400C ~ 600C

Humidity: < 90% RH

#### **4.13 DIMENSION AND WEIGHT**

140×52×48mm, approximately 500g

#### **4.14 CONNECT WITH PC**

RS232 serial communication

#### **4.15 CONNECT WITH PRINTER**

Connect with Time TA series printers only. TA210 printer only prints parameters. TA220s can print parameters as well as profile figures.

## 5 GENERAL MAINTENANCE

- Avoid crashes, intensive vibration, heavy dust, humidity, grease stains and strong magnetic fields;
- The sensor is a precise part and should be protected carefully. It is recommended to put it back in the box after each operation;
- Protect the standard sample plate belonging to the instrument carefully to avoid calibration faults caused by scratches.

### 5.1 TROUBLESHOOTING

When the instrument breaks down, try to solve the problems according to the next section Fault Information. If you cannot solve the problem yourself, please return the instrument to the factory for repair. Users should not dismantle or repair the device by themselves. Returned instruments shall be accompanied with a warranty card and a sample plate. The problem shall be explained.

### 5.2 FAULT INFORMATION

Table 6

<b>Display Content</b>	<b>Cause</b>	<b>Solutions</b>
Exceed Stroke	Maximum value of measured signal exceeds	<ol style="list-style-type: none"> <li>1. Press Esc key to return;</li> <li>2. Enter menu setting status, increase range of stroke, press Esc key to return;</li> <li>3. Measure again.</li> </ol>
No measurement data	Wrong operation results in failed measurement	<ol style="list-style-type: none"> <li>1. Press Esc key to return;</li> <li>2. Check if preparation for measurement is correct;</li> <li>3. Switch on and measure again.</li> </ol>
A/D Chip Error	Hardware circuit fault	Scheme 1: Switch off and switch on again; Scheme 2: Press Reset key; Scheme 3: Return to factory to repair.
Motor Blocked	Mechanical fault	Scheme 1: Switch off and switch on again; Scheme 2: Press Reset key; Scheme 3: Return to factory to repair.
Sensor In Return	Sensor is in automatic return process	<ol style="list-style-type: none"> <li>1. Press Esc key to return and wait until sensor to return to the start position;</li> <li>2. Measure again.</li> </ol>

## 6 RESET

When troubles are beyond the above section Fault Information and can not be solved, press Reset key to restore the device (as shown in figure) and all data and setting values will recover to default status.

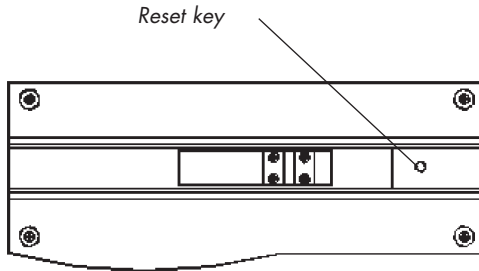

Figure 6-1 Reset



## 7 REFERENCES

### 7.1 PROFILE AND FILTER

#### 7.1.1 Profile

- a. Original profile: non-filtered profile signal obtained by sensor from measured surface.
- b. Filtered profile: profile signal after original profile is filtered to remove waviness.

#### 7.1.2 Filter

- a. RC filter: traditional 2-stage filter with phase difference;
- b. PC-RC filter: RC filter with phase-correction;
- c. Gauss filter: DIN4777
- d. D-P non-filtered profile: adopt central line of Least Square Algorithm.

### 7.2 CENTRAL LINE

TR-200 adopts minimum central line of Least Square Algorithm.

### 7.3 LENGTH OF DRIVING STROKE

#### 7.3.1 RC Filter

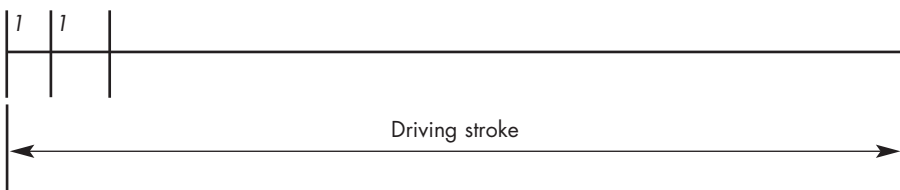

#### 7.3.2 PC-RC Filter

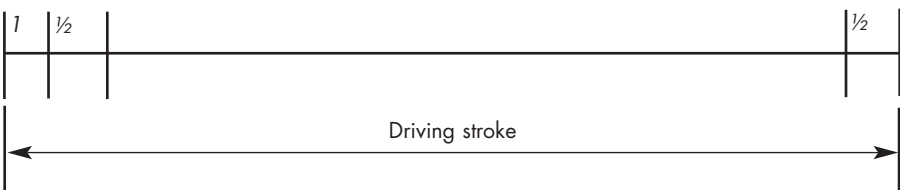

### 7.3.3 Gauss Filter

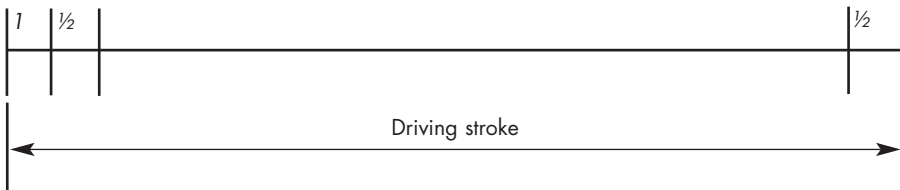

### 7.3.4 D-P Direct Profile

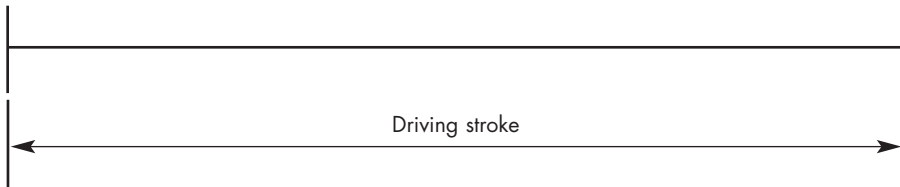

## 7.4 DEFINITION OF TR-200 ROUGHNESS PARAMETER

This section gives a definition of TR-200 measurement parameters.

### 7.4.1 Ra Arithmetical Mean Deviation of Profile

Arithmetic value of mean deviation of profile within sampling length.

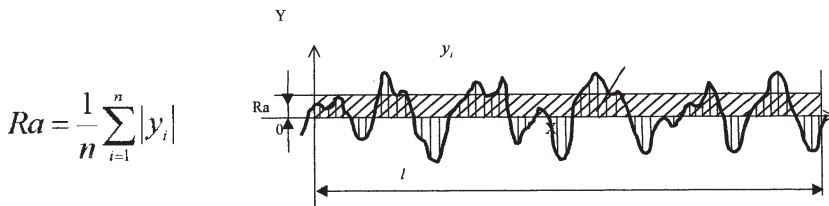

### 7.4.2 Rq Root-mean-square Deviation of Profile

$$Rq = \left( \frac{1}{n} \sum_{i=1}^n y_i^2 \right)^{\frac{1}{2}}$$

Root-mean-square of profile deviation within the sampling length, shown as the following function:

### 7.4.3 Rz Ten Point Height of Irregularities

$$Rz = \frac{\sum_{i=1}^5 y_{pi} + \sum_{i=1}^5 y_{vi}}{5}$$

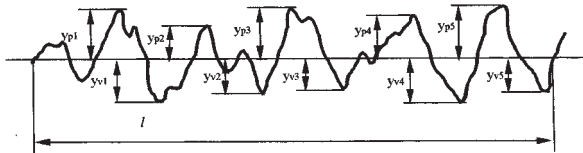

The average of the sum of five maximum profile peaks and the average of five maximum profile valley within the sampling length.

### 7.4.4 Ry (ISO) Maximum Height of Profile

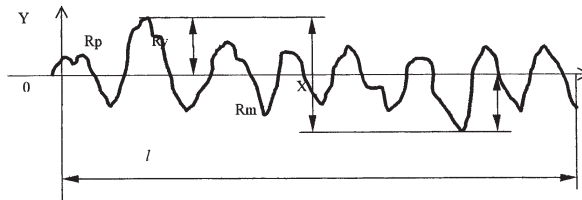

The distance from the profile peak line to valley line within sampling length.

#### 7.4.5 Ry (DIN) Maximum Height of Profile

To get Ry (DIN) value: first calculate the distance between the profile peak line and the valley line in each sampling length, of which the maximum is the Ry (DIN) for the evaluation length.

#### 7.4.6 Rt Total Peak-to-valley Height

Rt is the sum of maximum height of the profile peak and maximum depth of the profile valley for the evaluation length.

#### 7.4.7 Rp Maximum Depth of Profile Peak

Rp is the distance from the profile peak line to the median line within the sampling length.

#### 7.4.8 Rm Maximum Depth of Profile Valley

Rm is the distance from the profile valley line to median line within sampling length.

#### 7.4.9 Sm Mean Spacing of Profile Irregularities

$$Sm = \frac{1}{n} \sum_{i=1}^{i=n} Si$$

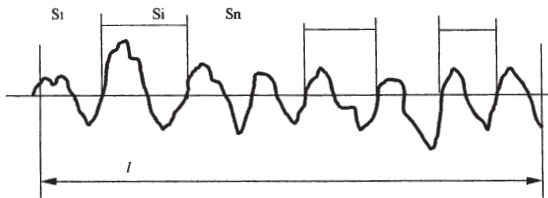

Mean spacing of the profile irregularities within sampling length.

### 7.4.10S Mean Spacing of Local Peaks of Profile

Mean spacing of local peaks of the profile within sampling length.

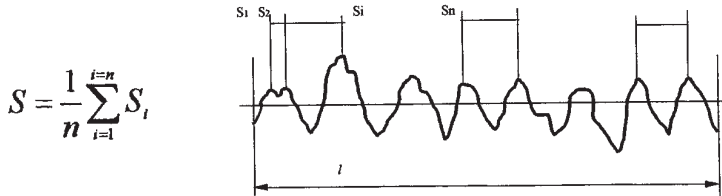

### 7.4.11 tp Profile Bearing Length Ratio

The ratio of profile bearing length to the sampling length.

$$tp = \frac{\eta_p}{l}$$

$$\eta_p = b_1 + \Lambda \Lambda + b_i + \Lambda \Lambda + b_n$$

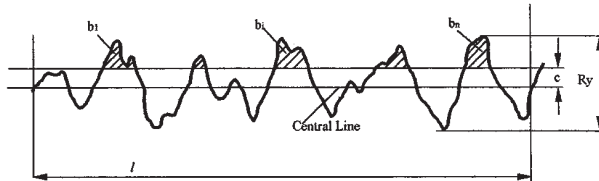

### 7.4.12Sk Skewness of the profile

$S_k$  is the measurement of asymmetry of amplitude, defined by the mean of cubed profile deviation within sampling length. Refer to the following function:

$$S_k = \frac{1}{R_q^3} \times \frac{1}{n} \sum_{i=1}^n (y_i)^3$$

### **7.4.13R<sup>3z</sup> Third Maximum Peak-to-valley Height**

R3z is the sum of the third profile peak height and the third profile valley depth of each sampling length within evaluation length.



CV Instruments Europe BV







CV Instruments Europe BV

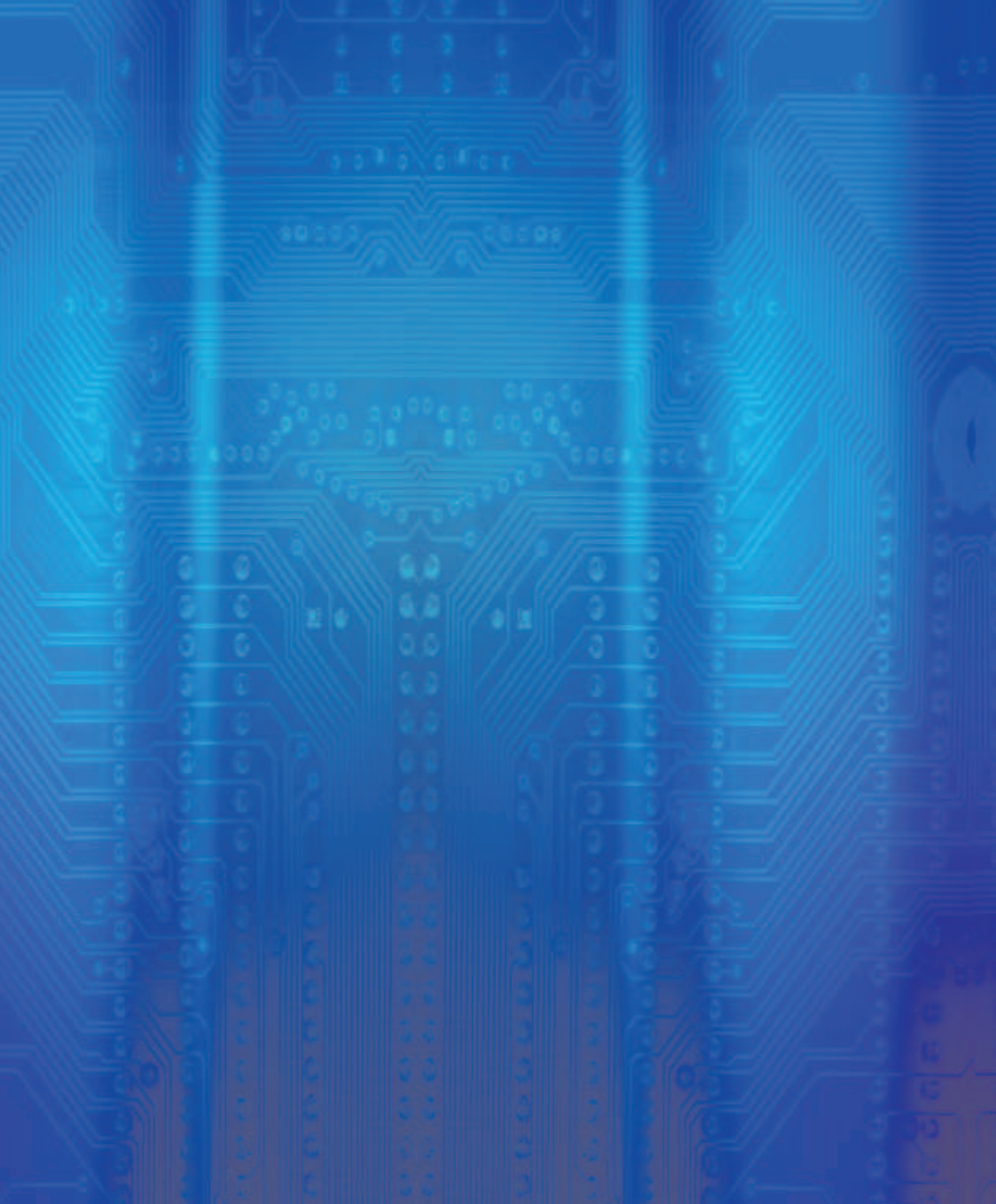

CV05-053