

Model

TVC-7 VISCOMETER



responding swiftly to your needs

Unrivalled convenience! Easy on-site viscosity measurement.

Operation display

- * Measurement underway
- Measurement stopped

Measurements value

Top line: viscosity
Bottom line: %
("OVER" scale indication)



Rotor No.

Measurement time counter

Message display area
(LB, etc)

Display

Item	LCD Display	Description
Measurement value	mPa·s/Pa·s	Viscosity
	%	Indicator reading
Rotor no.	R0~R5	Indicates rotor no.
Measuring time counter	P0~P99	Displays time count in approx. 1 sec. increments, up to max. 99 (used as a rough guide)
Measurement underway	*	Blinks when measuring
Measurement stopped	→	Freezes measurement value
Over scale	OVER	Indicates when measurement range is exceeded
Low battery	LB	Power automatically turned OFF approx. 1 hour after indicator starts blinking

The new handy type Model TVC-7 rotary viscometer provides worry-free viscosity measurement and unmatched convenience. Designed for enhanced ease of use and low power consumption, this advanced viscometer can be used for long hours without worrying about loss of battery power making it an invaluable partner in production on-site quality control applications.

Handy type design

Measure viscosity anywhere

Digital display

Reliable readouts of measured values

Easy to see display

Two-line LCD displays all data

Elapsed time display

Elapsed measurement time display

Independent control keys

Only 3 control keys for easy measurement

Cordless design

Smartly designed unit houses batteries

Drop protection

Slip-resistant grip and wrist strap prevents accidental dropping

Power saving design

Number of batteries reduced from 4 to 3 with approx, fourfold increase in continuous operation time. (Compared to Model TVC-5)
Auto Power-Off function extends battery life.



Specifications

Speed	20rpm
Accuracy	Less than $\pm 3\%$ of full scale (Rotor No. 2,3,4) Less than $\pm 4\%$ of full scale (Rotor No. 0,1,5)
Repeatability	Less than $\pm 2\%$ of full scale
Measurement value display	Digital, 3 digits
Measurement units	SI units (mPa · s/Pa · s), % value simultaneously displayed
Operating temperature range	5~40°C
Operating humidity range	Less than 90% RH (non-condensation)
Power	Type 2 (size 'C') batteries $\times 3$ pcs
Continuous operation time	Approx. 30 hours (at 25°C ambient temperature, with new alkaline batteries)
Wetted parts material	Stainless steel
Case material	Molded PBT resin
Weight	1.4kg (including batteries, guard)

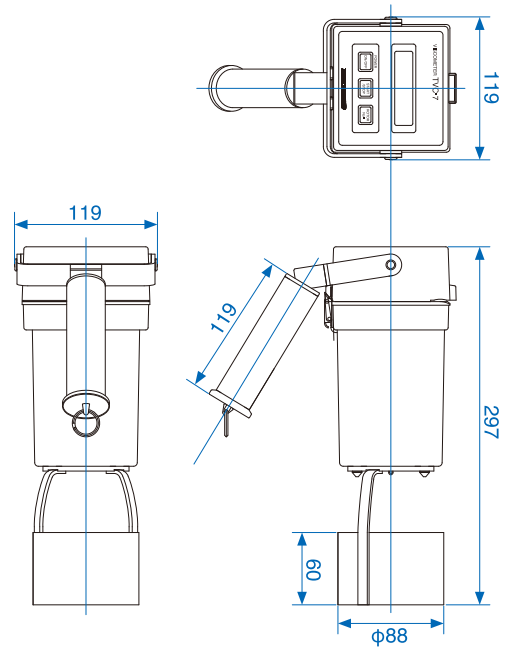

In case of being in need of AC Adaptor, please prepare it according to below specifications.

- Specification of AC adaptor:
 - Output: 6V DC 100mA or more
 - DC Power jack name : EIAJ-3 (+pole pin diameter f 1.65, -pole hole diameter f 5.15)

*Please do not use the AC adaptor without a CE marking.

- Electrical Certifications: CE

Options

■ Rotor

Select according to desired measurement range



[Rotor Upper Limit Value] (Unit:mPa · s)

Speed Rotor	20rpm
No. 0	100
No. 1	500
No. 2	2,000
No. 3	10,000
No. 4	50,000
No. 5	200,000

※Lower limit is 10% of above values.

※All rotors are options.

■ Carrying Case

Use for storage, transport



■ Stand Set



☆ Precautions for safeguarding unit

The TVC-7 is not moisture or water-resistant nor of hermetically-sealed construction.

Do not allow sample fluids or cleaning solvents to enter the case.

Do not use unit in locations subject to high temperatures or corrosive atmospheres.

※ Product specifications and design are subject to change or modification without notice.

⚠ Warning: do not operate equipment in flame or explosion-hazardous location

⚠ Caution relating to safety: manual should be thoroughly read before use and equipment should be operated and handled in the prescribed correct manner.

